

R.
2 0
2 4

B K K | T H A I L A N D

2 0
2 4

**WE ARE A TEAM OF DESIGNERS WITH
MULTI-DISCIPLINARY FIELDS FROM VISUAL
IDENTITY, GRAPHIC DESIGN, PACKAGING
TO EXPERIENCE DESIGN AND LIGHTING ART
INSTALLATION. ALWAYS DOING OUR BEST
AS OUR WORK AND PLAY IS COMBINED.
WE'D LOVE TO HEAR ABOUT YOUR STORIES
AND BUSINESSES. LET'S EXPLORE DESIGN
SOLUTIONS AND OPPORTUNITIES, TOGETHER.**

R.

Design consultant service
in branding and experience
design.Bangkok, Thailand.

47 Soi Nakniwat 37 rd.
Nakniwat Rd, Ladprao,
Bangkok Thailand 10230

Call : (+66)65.635.9453
Mail : contact@roundandnine.com

OBJECTIVE

To **REFRESH** the brand, making it distinctly recognizable and memorable in a crowded market, without sacrificing the commitment to results and innovation.

PROCESS

Create a unique **STORY** and **VISUAL** to differentiate from the red ocean.
Gathering insights via In-depth interview and Market Researches.
Exploring the possibilities of Brand Statement and Persona.

GOAL

DISTINCTIVE Message From Competitors
Easy To Understand / **TRUSTED** By Client
Feel **PROUD** By Team

BRAND

STORY

VISUAL

STORY

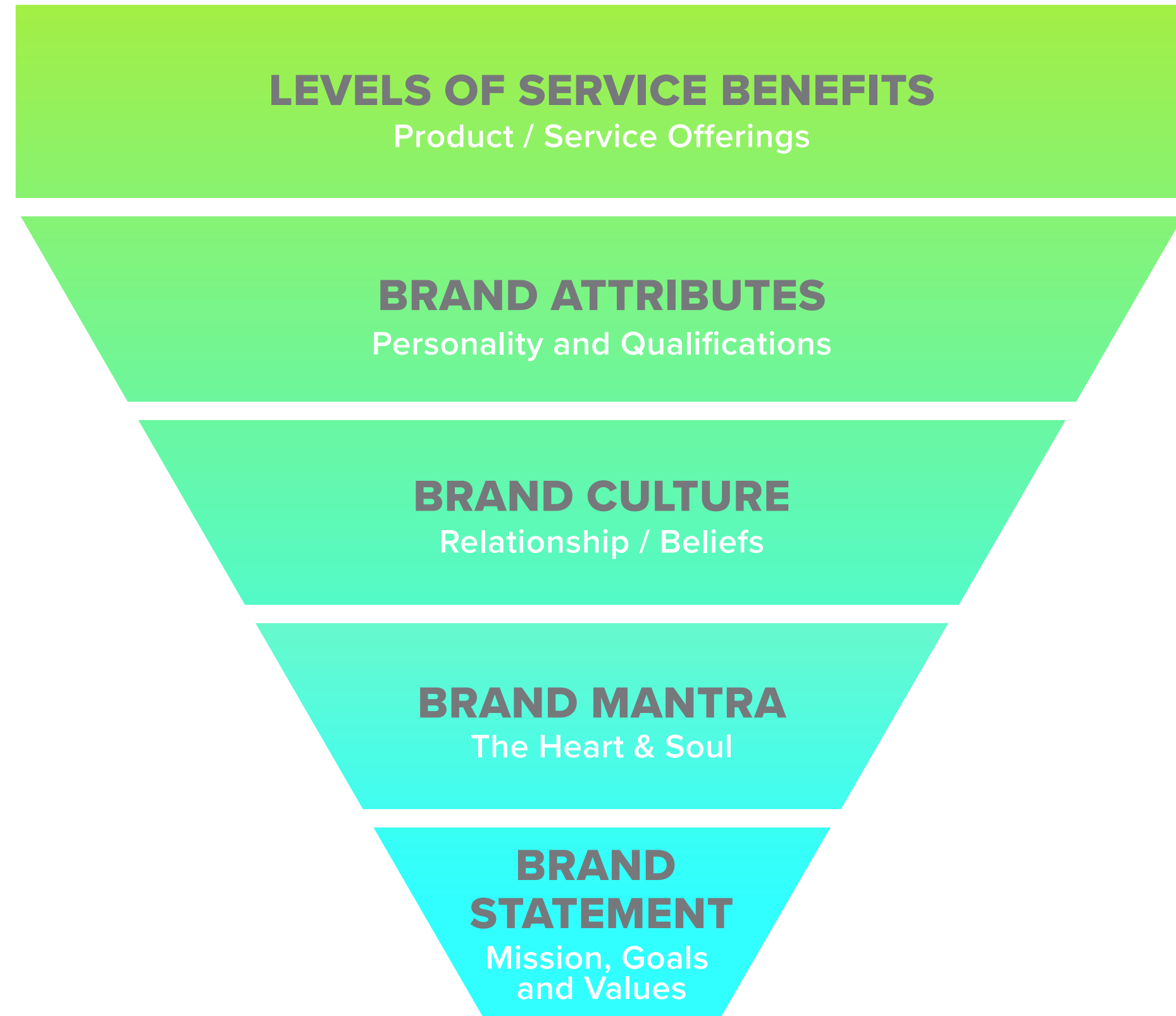

VISUAL



Crafting a unique story involves a combination of creativity, structure, and a deep understanding of yourself and your audience.

STORY

EXTERNAL COMPONENTS
+ MARKET POSITIONING
+ COMPETITOR ANALYSIS
+ CLIENT ANALYSIS

INTERNAL COMPONENTS
+ UNIQUE SELLING POINTS
+ POP & POD

PREFERENCES
+ ASPIRATION



VISUAL

CORPORATE IDENTITY

- + LOGO
- + COLORS
- + TYPOGRAPHY
- + GRAPHIC ELEMENTS

ONLINE COMM

- + WEBSITE
- + SOCIAL TEMPLATE
- + DIRECT MAILS NEWSLETTER

OFFLINE COMM

- + COMMUNICATION MATER.
- + ENVIRONMENTAL GRAPHIC



Introducing new Business Unit of **KING POWER** Family

Associating to the **Digital Tech industry** and other players

Communicate **CLICK Characteristics** and Company **Culture**

DESIGN CRITERIA

2024



START UP OVERVIEW

The 'START UP OVERVIEW' section is a comprehensive grid of logos. It is organized into several categories:

- Notable Startups:** A large grid of logos including Priceza.com, Wongnai, bukk, Jitta, Oossee, SINOZE, StockRadar, bilisby, Pomelo, Refinn digio, FINNOMENA, WISHBEER, #links, Orami, fastwork, Deep Food, FIXZY, INFINITY LEVELS, Omise, DENTAL EXPERTURES, finance, eabigo, SkillLane, golfdigg, hipflat, Zilingo, and 202P.
- Government:** Logos for SIPA, EGA, ETDA, SEC, NIA, DBD, SOFTWARE PARK, ICT, and mai.
- Venture Capital:** Logos for 500, dtac, InVent, ascena, Tencent, ANANDA, SANSIRI, SCG, K2 VENTURE, DMP, GALAXY VENTURES, Golden Gate Ventures, COL, Ventures, MONK'S HILL, RECRUIT, DeNA, docomo, SUMITOMO CORPORATION, Double A, jungle, GB, JADEUS, I14 INVESTMENT PARTNERS, mas partners Pte.Ltd., and innov8.
- Tech Companies (IPO or M&A):** Logos for OfficeMate, THINK OF LIVING, MOXY, one2ear, ASIASOFT, PAYSBUY, Kaidee, and PHAEPAY.
- Venture builders:** Logos for ardent labs and Yrabil internet.
- Incubators / Accelerators:** Logos for AIS StartUp, true incubate, dtac, Krungsri RISE, BIC, and JADEUS.
- Tech Media:** Logos for TECHSAUCE, BYELINE, and plognone.
- Event:** Logos for TECHSAUCE, ongethock, STARTUP THAILAND, BANGKOK, and ECHOLON THAILAND.
- Co-working space:** Logos for the Elve.
- Startup Association:** Logos for stock2morrow and Venture Club.
- Angel Groups / Clubs:** Logos for stock2morrow, Venture Club, and shift.
- Education:** Logos for WE SYSTEM.

SOURCE : [HTTP://TECHSAUCE.CO](http://TECHSAUCE.CO)

START UP FAMILY

The 'START UP FAMILY' section displays logos from various major Thai corporations and their associated startup initiatives:

- Telecommunications:** true, trueINCUBE, AIS, AIS THE StartUP, dtac, dtac accelerate, Singtel, Singtel innov8.
- Banking & Finance:** ANANDA DEVELOPMENT, ANANDA URBANTECH, SANSIRI, SIRS VENTURE, SCG, Add Ventures by SCG, COL CENTRAL ONLINE, CPN, cmg, KASIKORN BANK, KRUNGSRI, RISE, SCB, beacon venture capital.
- Other:** SANSIRI, SIRS VENTURE, ANANDA DEVELOPMENT, ANANDA URBANTECH, SCG, Add Ventures by SCG, COL CENTRAL ONLINE, CPN, cmg, KASIKORN BANK, KRUNGSRI, RISE, SCB, beacon venture capital.



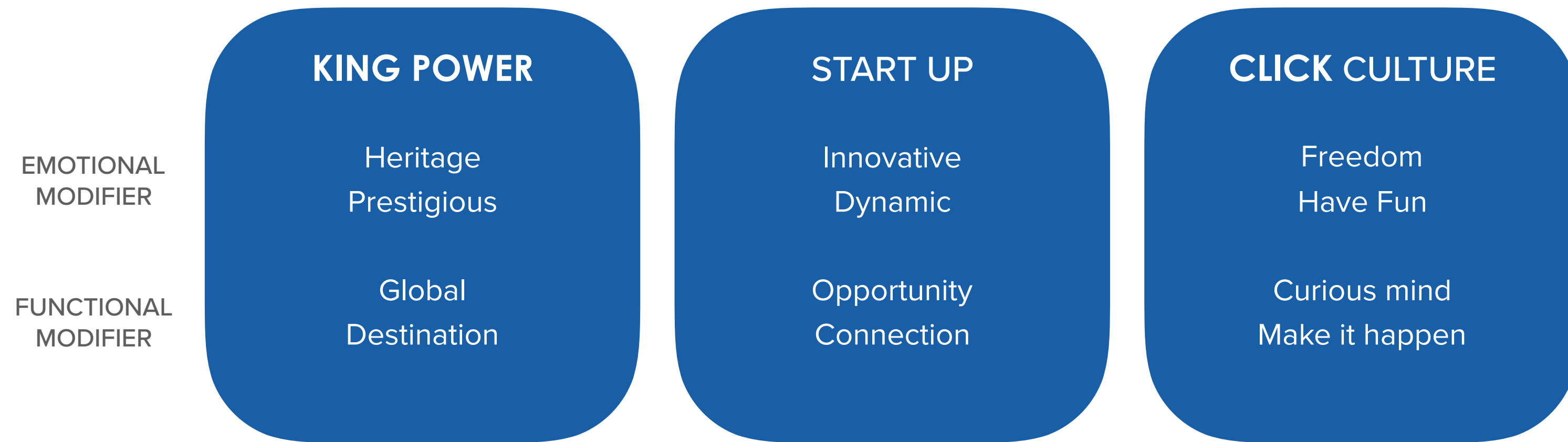

BRAND POSITIONING

2024

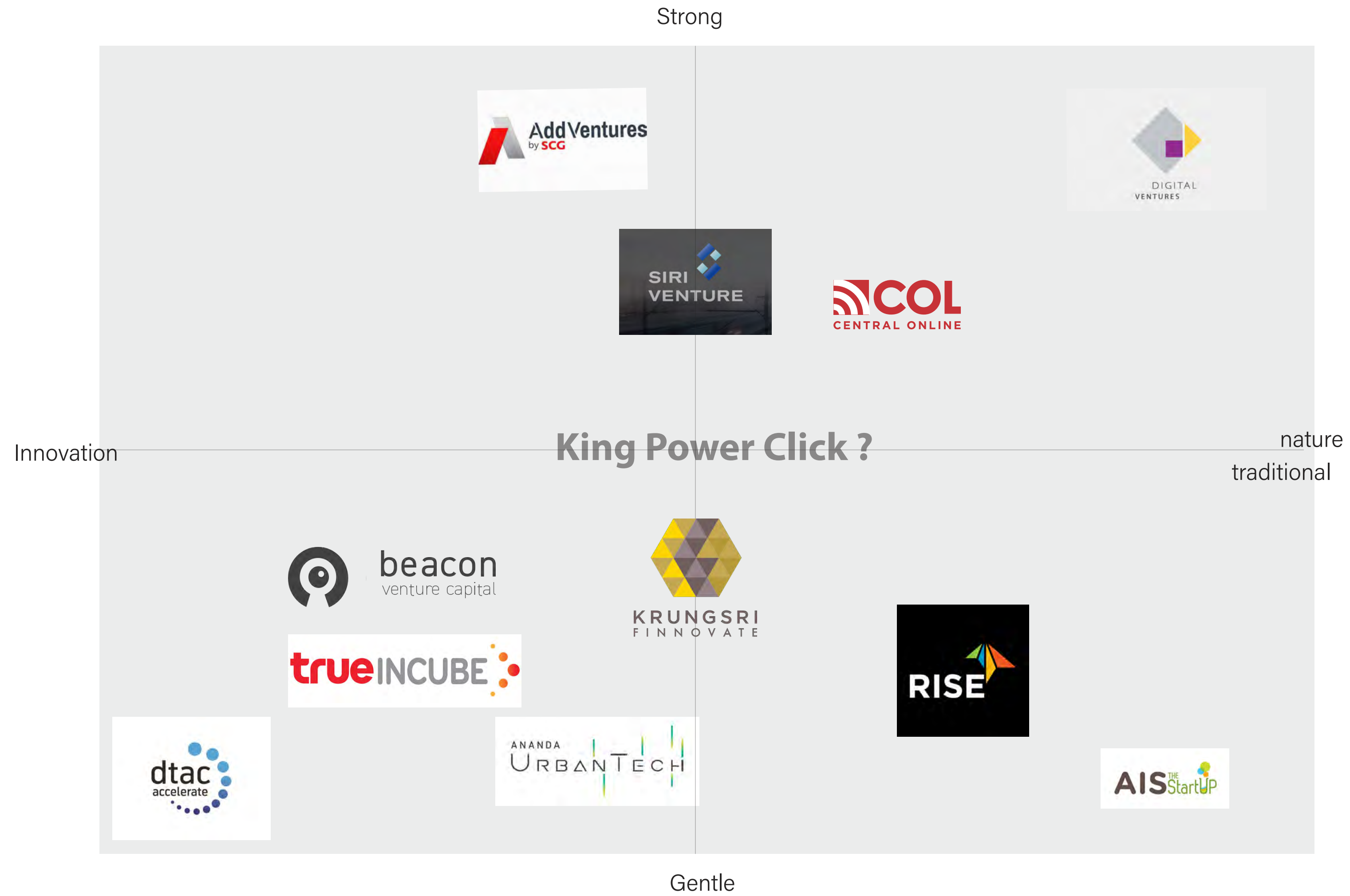

DESIGN OBJECTIVE

2 0
2 4

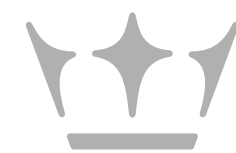
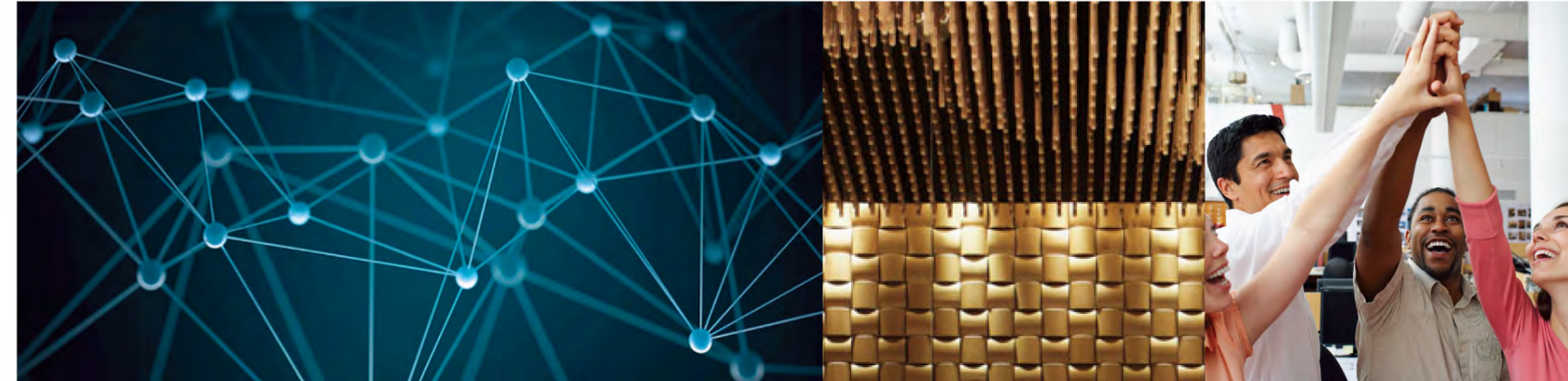
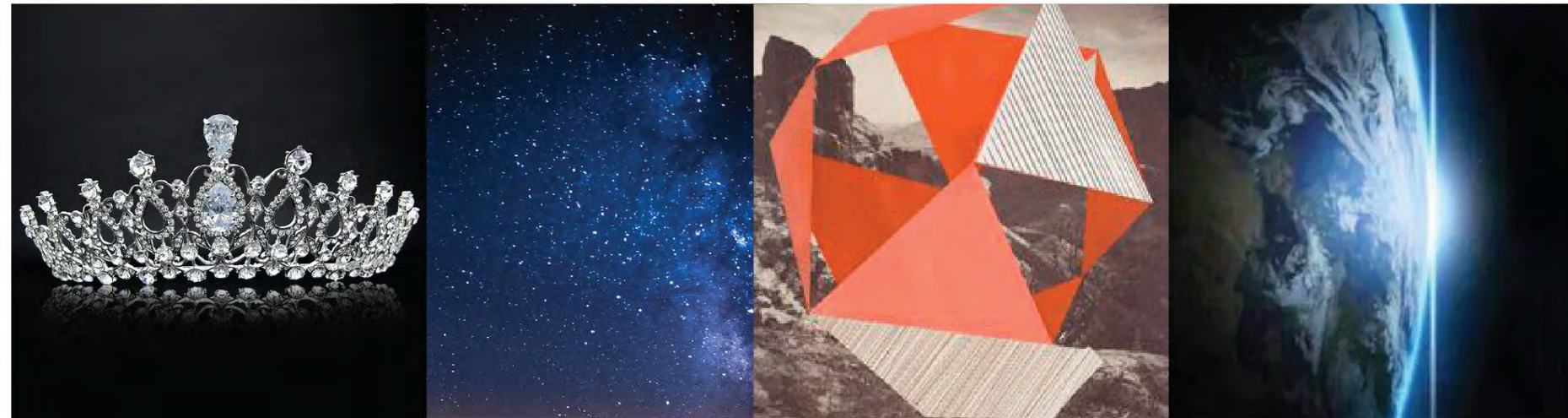

CROWN DIAMOND JUBILEE PRESTIGIOUS RECOGNITION

PRESTIGE VICTORY TRIUMPH GLORY

BRAND STATEMENT

 **KING POWER**

WE ARE TRAVELING TOOL

สร้าง / โอกาส / ให้ / เป็นจริง

DOING

Duty free online
Market place - Shop spot
Advertorial online
Tech Grooming

PEOPLE

Freedom / No Boundaries
Marketing Savvy /
Younger Generation of KP

BRAIN STROMING

2 0
2 4

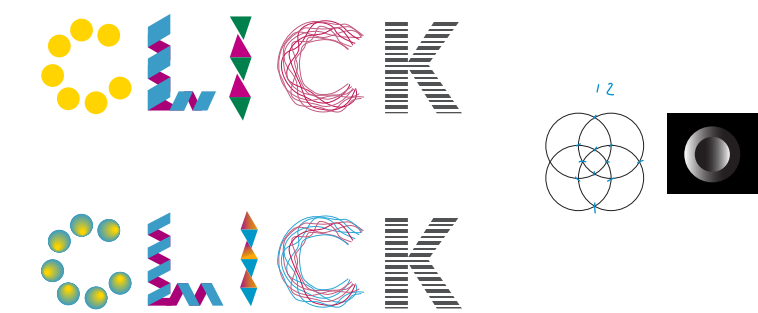
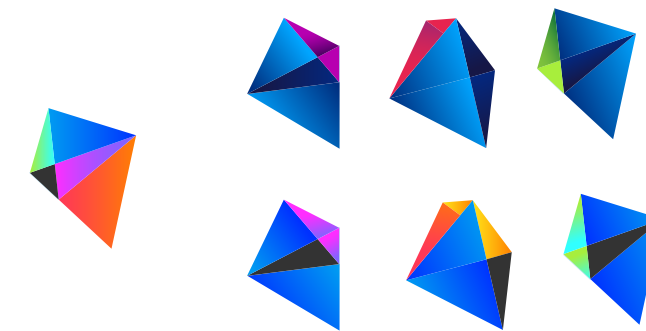
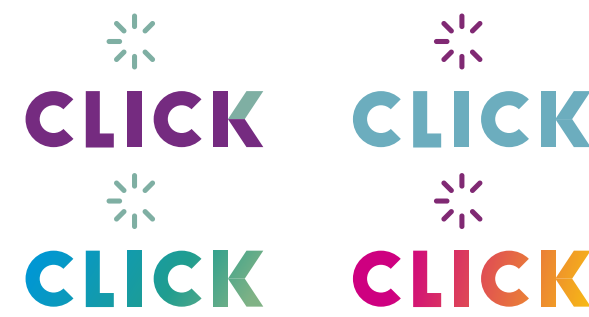
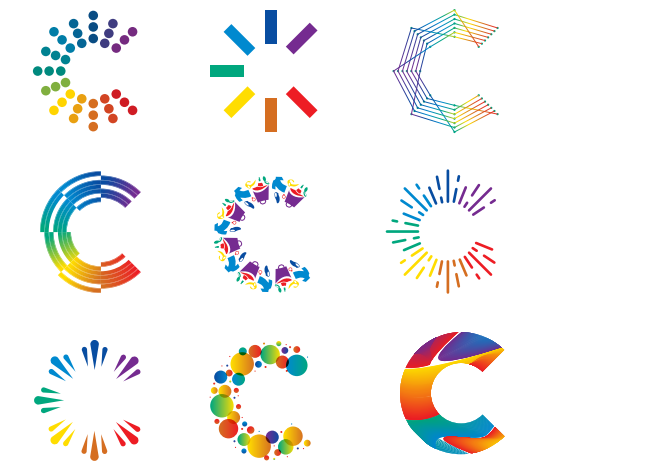
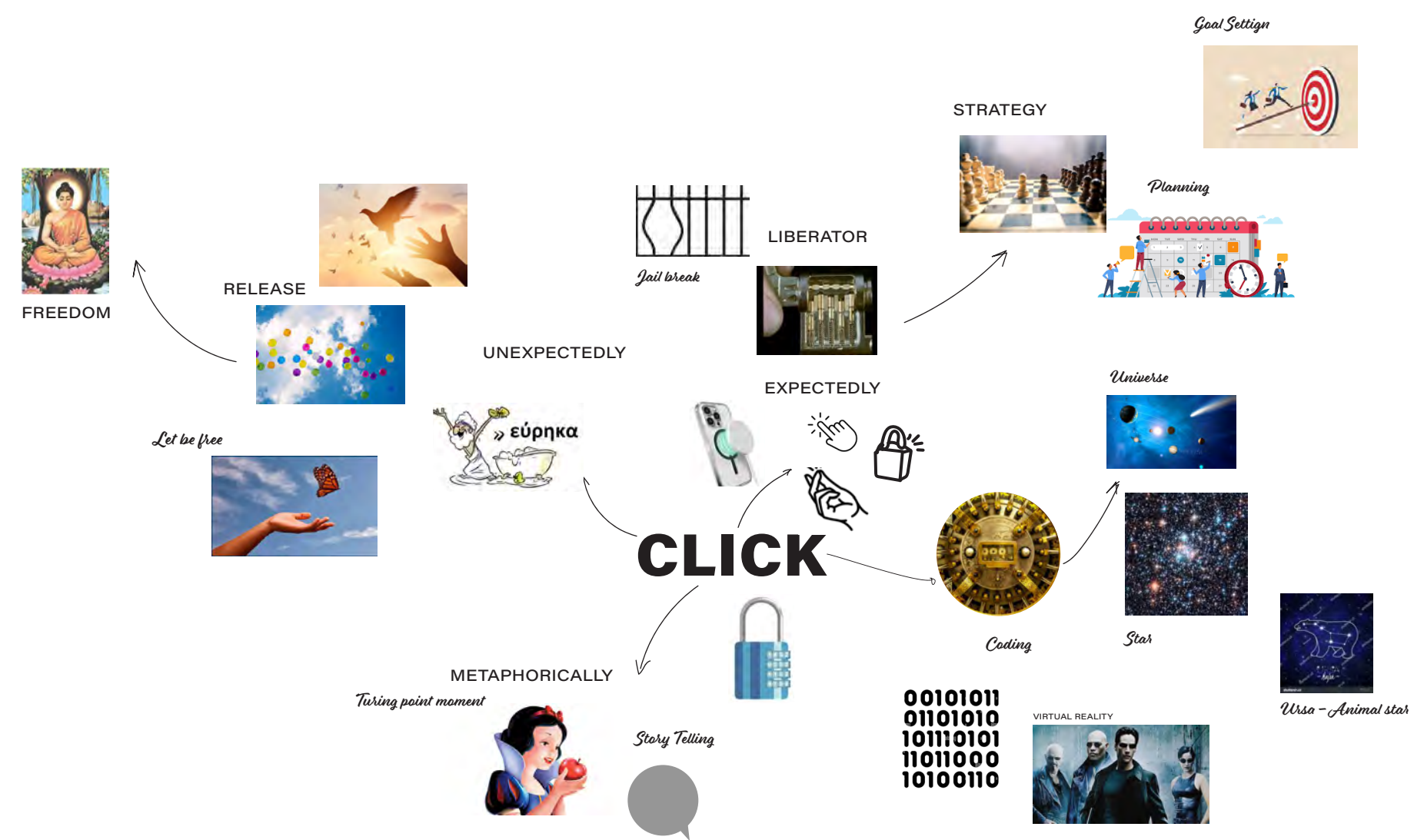

IDEATION

2 0
2 4

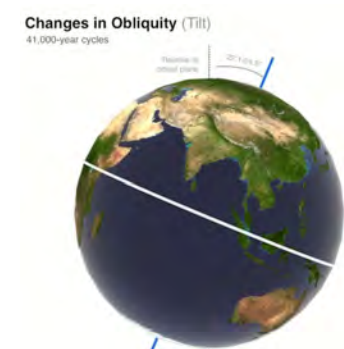
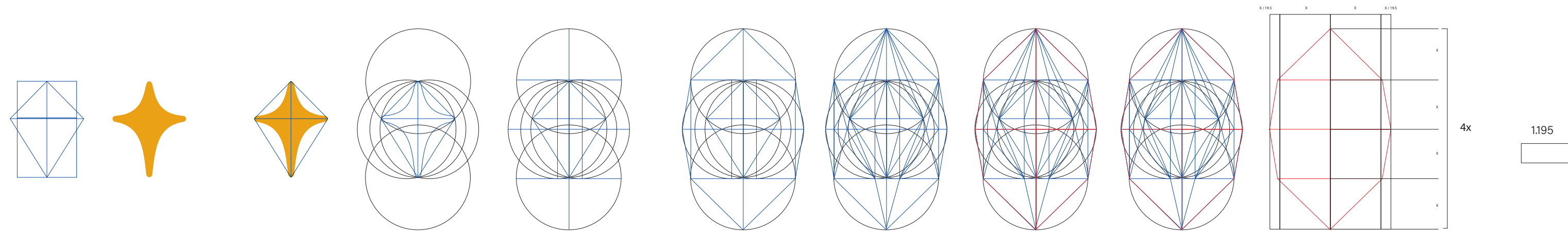

FOR EACH SURFACE





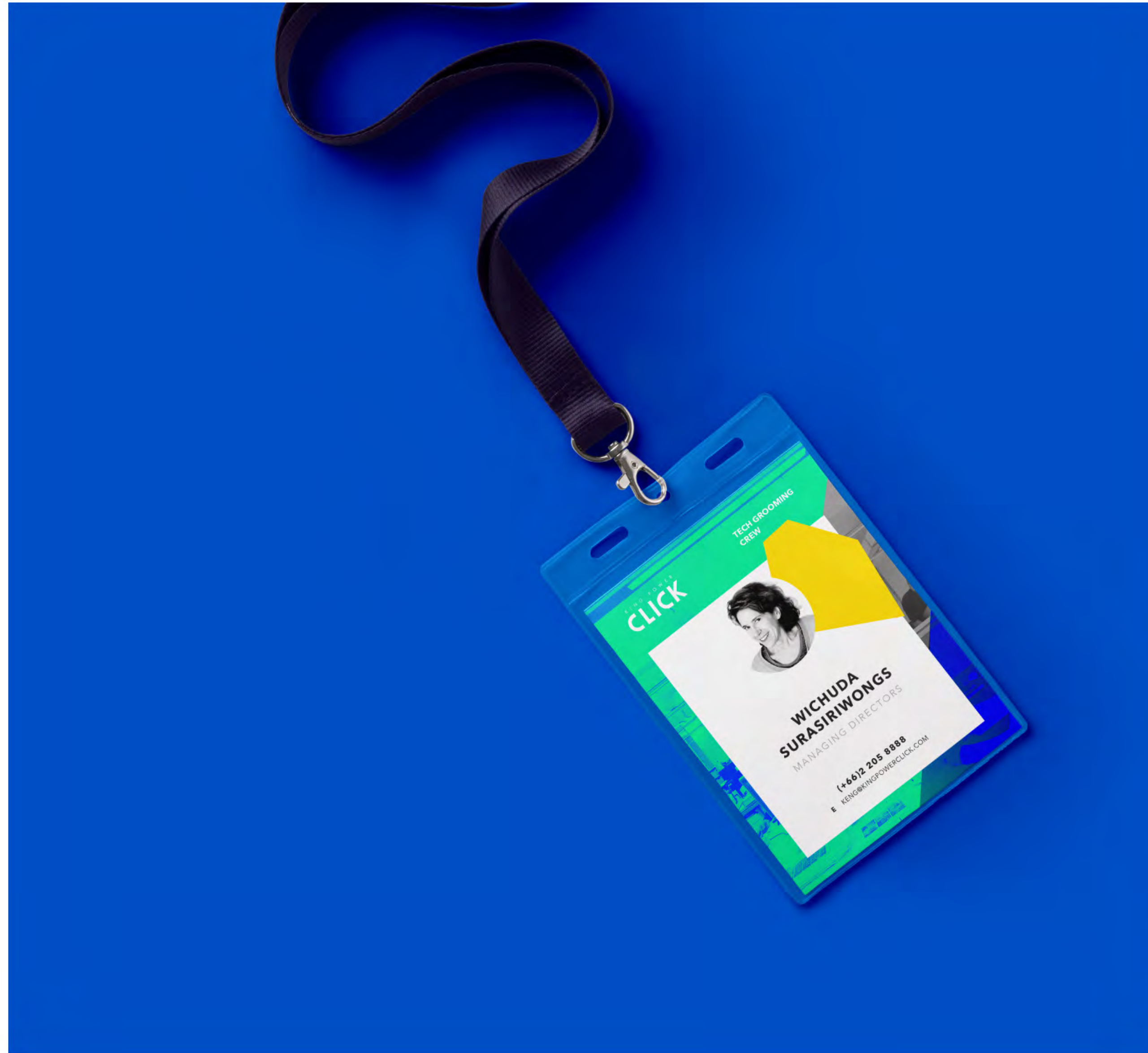

MAKE A DIFFE- RENCE

*BIG DATA
ANALYTIC
TECH* Yamamoto Kusiji,
WORLD DATA ANALYTIC.co.th

18.03.18

@ Aksra Theatre King Power



*TECH GROOMING
YOUR WAYS*

Kris Patterson, Ph.D
Tech Definition co.,Ltd

*FRESH
DISRUPTIVE
THINKING*

Michael Thompson, Ph.D
DE-Think co.,Ltd



ONLINE MARKET

Lorem ipsum dolor sit amet, consectetur adipiscing elit, sed diam nonummy nibh euismod tincidunt ut laoreet



BIG DATA ANALYTICAL TECH
Yamamoto Koji, CEO @KPT.com



FRESH DISRUPTIVE THINKING
Michael Thompson, Ph.D.

GREAT IDEA psum dolor sit amet, consectetur adipiscing elit, sed diam nonummy nibh euismod tincidunt ut laoreet dolore magna aliquam erat volutpat. Ut wisi enim ad minim veniam, quis nostrud exerci tation ullamcorper suscipit lobortis nisl ut aliquip ex ea commodo consequat. Duis autem vel eum iriure dolor



IDEA GENERATIONS

Lorem ipsum dolor sit amet, consectetur adipiscing elit, sed diam nonummy nibh euismod tincidunt ut laoreet dolore magna aliquam erat volutpat. Ut wisi enim ad minim veniam, quis nostrud exerci tation ullamco.

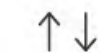

Lorem ipsum dolor sit amet, consectetur adipisaco.

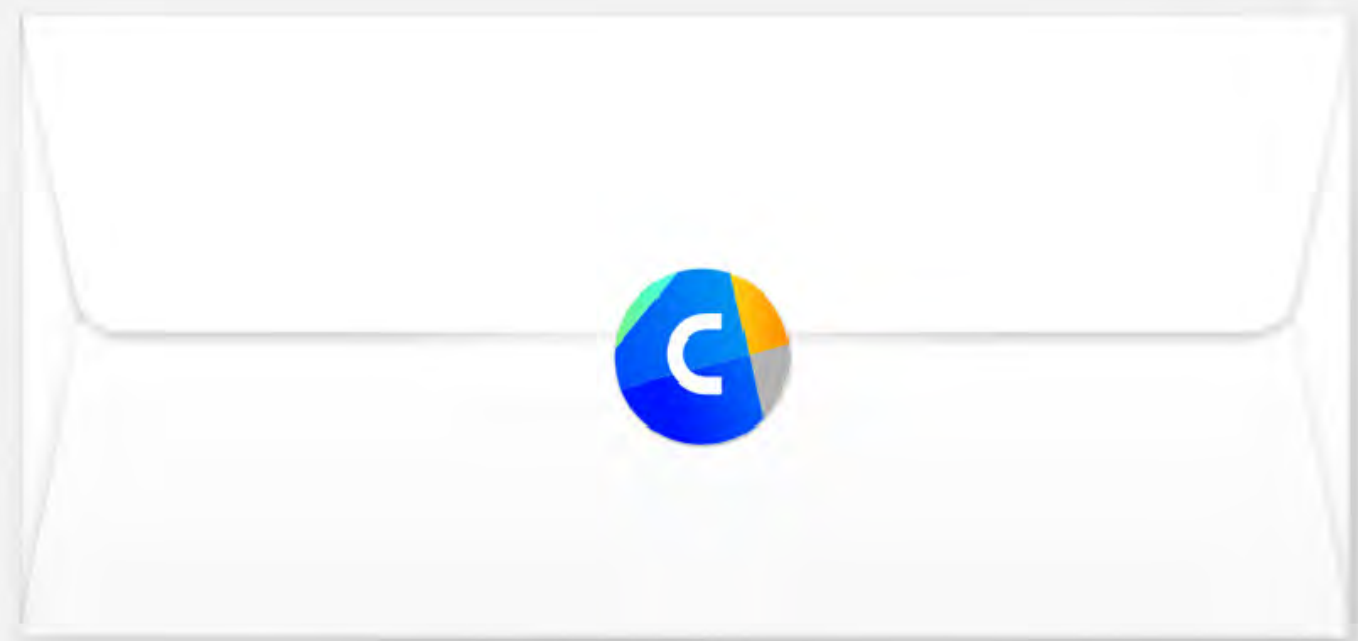

KING POWER CLICK

05.02.18

DESIGNED BY

VERTICAL LOGO

HORIZONTAL LOGO

LOGO ELEMENTS

CLEAR SPACE

MINIMUM USED SIZE

PRIMARY COLOR

CLICK BLUE (BASE)	CLICK BLUE (ALTERNATIVE)	CLICK GREEN (ALTERNATIVE)	CLICK ORANGE (ALTERNATIVE)	CLICK GREY (ALTERNATIVE)
RGB: 10 / 20 / 250 HEX: #0A1496	RGB: 20 / 124 / 240 HEX: #1477F0	RGB: 100 / 241 / 177 HEX: #66BB6A	RGB: 255 / 179 / 75 HEX: #FF9800	RGB: 128 / 128 / 128 HEX: #9E9E9E
PMS: 2865 C CMYK: 81 / 70 / 0 / 0	PMS: 649 C CMYK: 75 / 50 / 0 / 0	PMS: 664 C CMYK: 52 / 9 / 41 / 0	PMS: 122 C CMYK: 0 / 50 / 100 / 0	PMS: Cool Gray 4 C CMYK: 0 / 0 / 0 / 20

NEUTRAL COLOR

RGB: 255 / 255 / 255 HEX: #FFFFFF	RGB: 0 / 0 / 0 HEX: #000000
--------------------------------------	--------------------------------

PROCESS COLOR

VERTICAL LOGO

HORIZONTAL LOGO

SPOT COLOR

VERTICAL LOGO

HORIZONTAL LOGO

MONOCHROME

VERTICAL LOGO

HORIZONTAL LOGO

OPTIONAL COLOR (GRADIENT)

OPTIONAL COLOR (SINGLE COLOR)

OPTIONAL COLOR (SINGLE COLOR)

IMPLEMENTATION

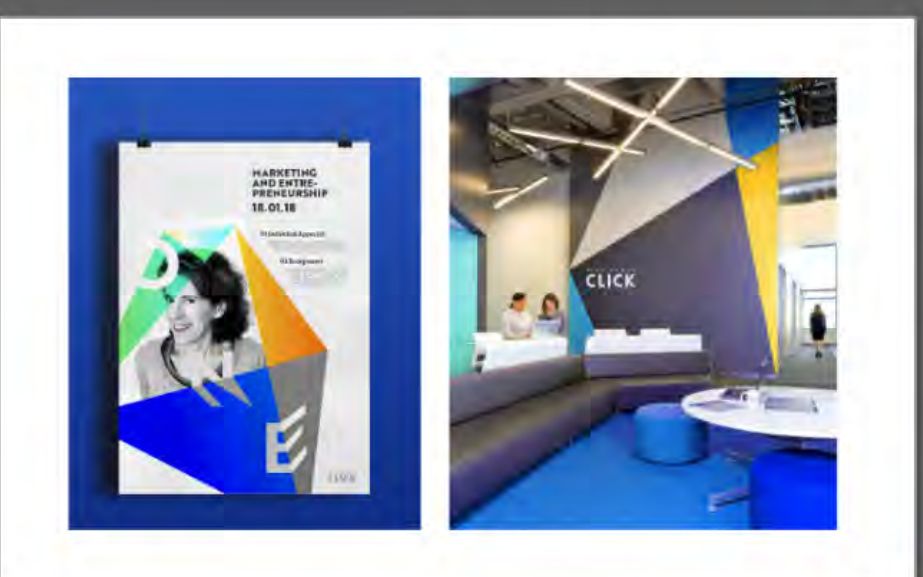
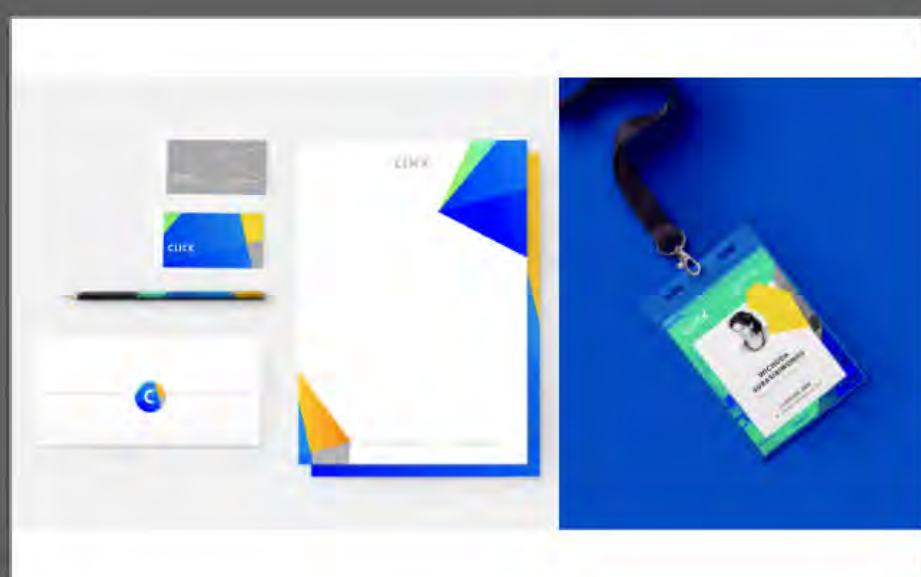
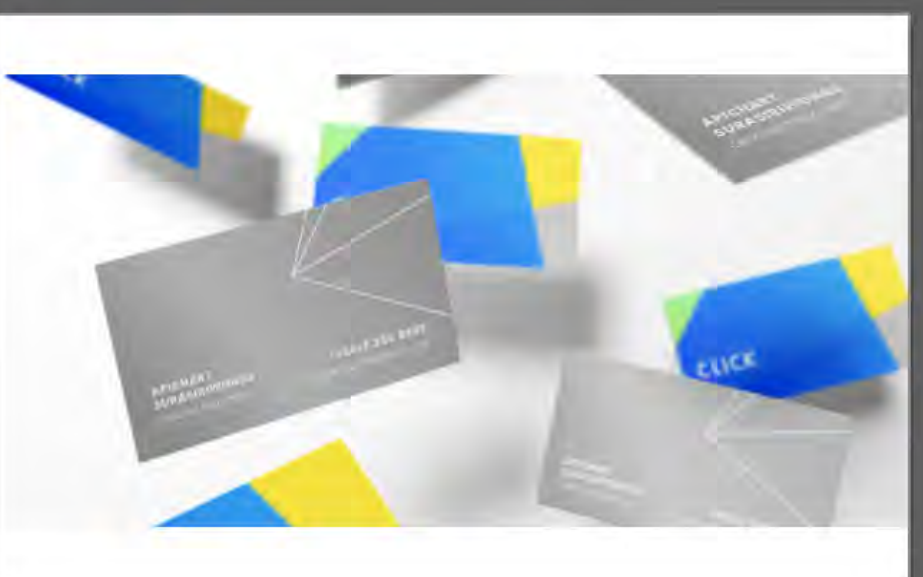

PREVIOUS DESIGN

2024



RE-BRANDING OBJECTIVES

2 0
2 4

Updating the Brand identity to associate with current market trend and lifestyle

Personify the brand and become more reachable for the end users

Strengthen the visual identity to support with product quality

The trustworthy, Thai Power Extension Brand
who was the first manufacturer and have been with Thai market for over 30 years

POSITIONING MAP

204
24

LOGO

PRODUCTS

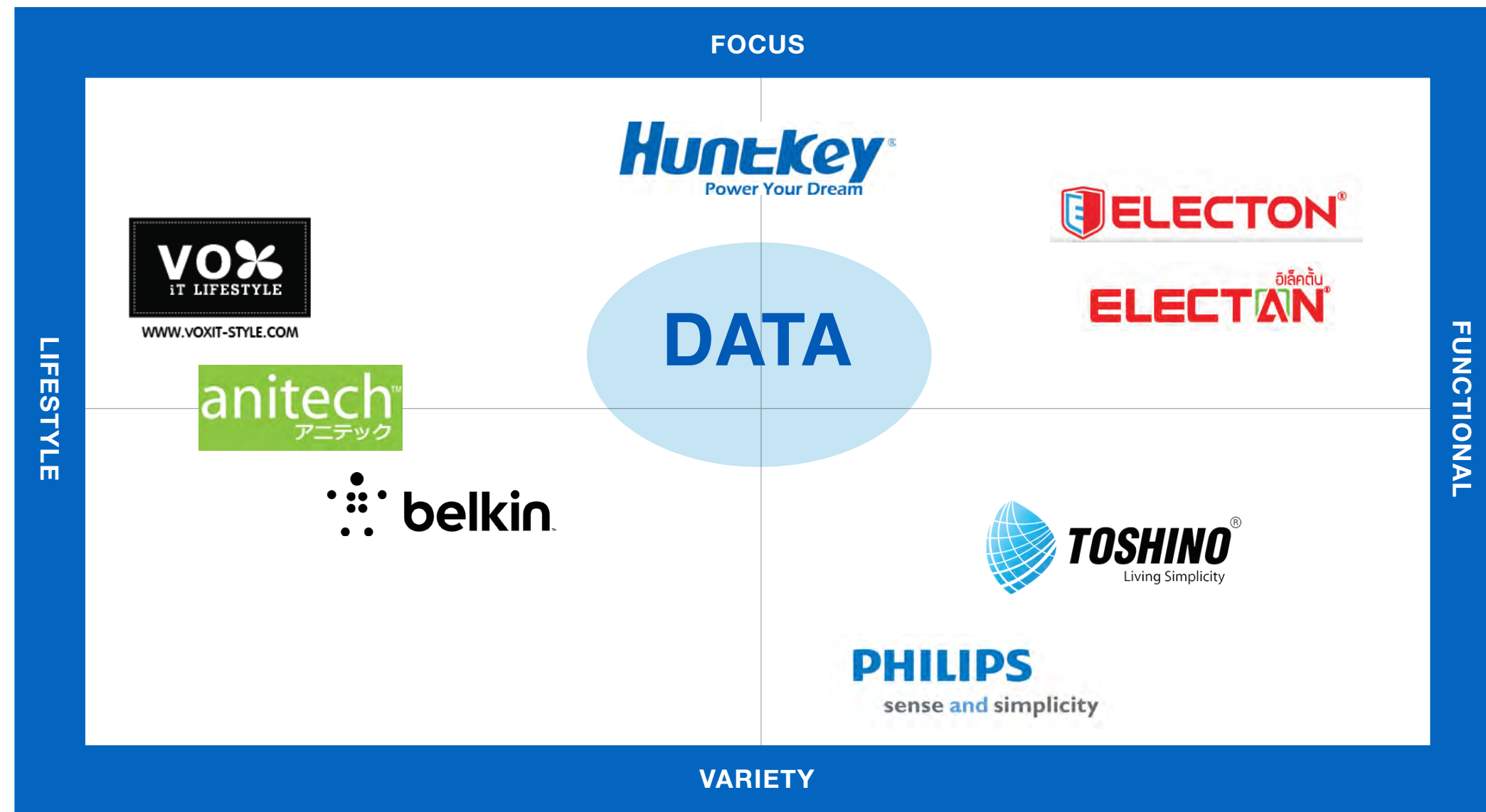

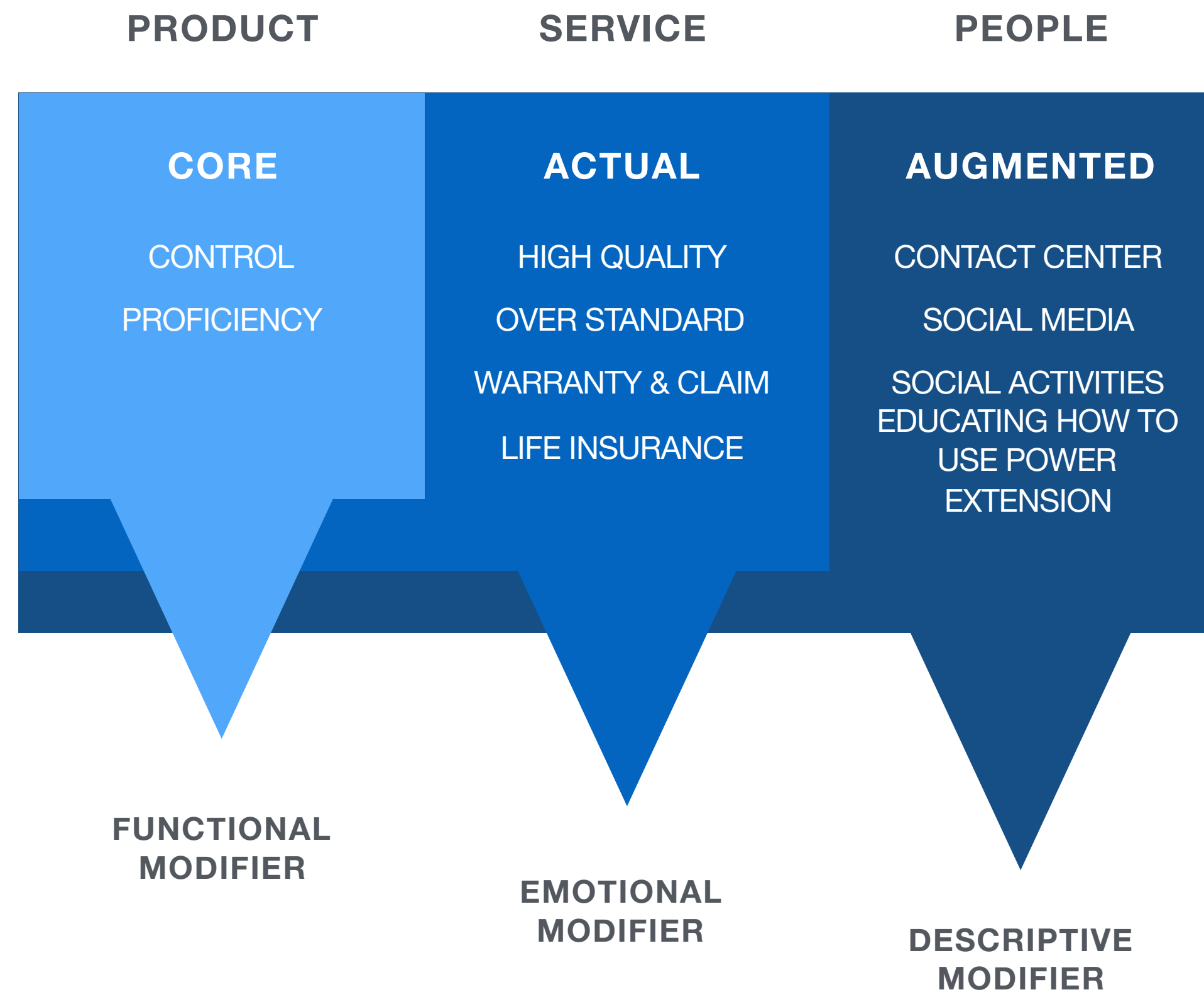

BRAND MANTRA & STATEMENT

2024

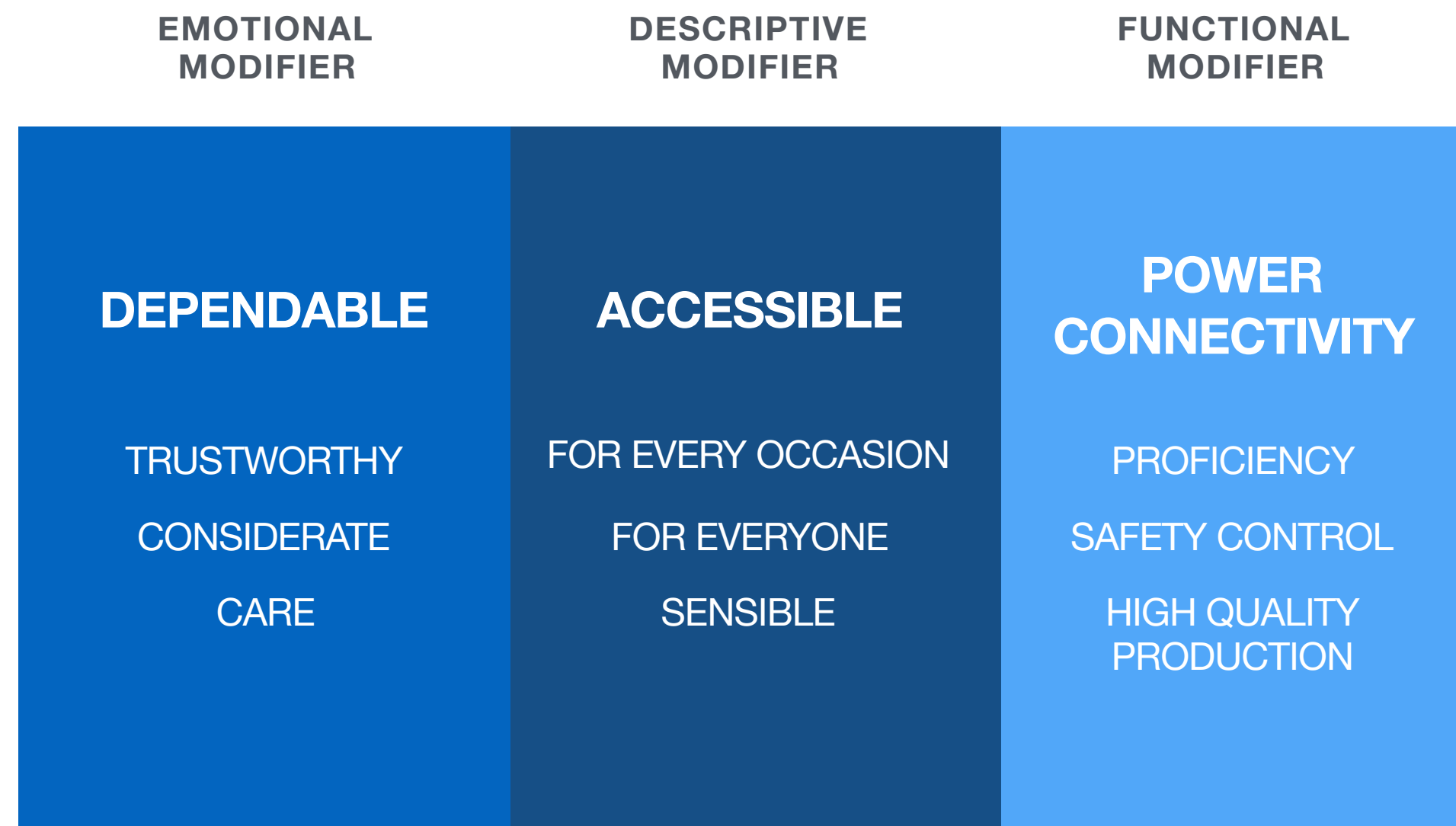

**THE TRUSTED POWER CONNECTIVITY
FOR EVERY MODERN LIFESTYLE**

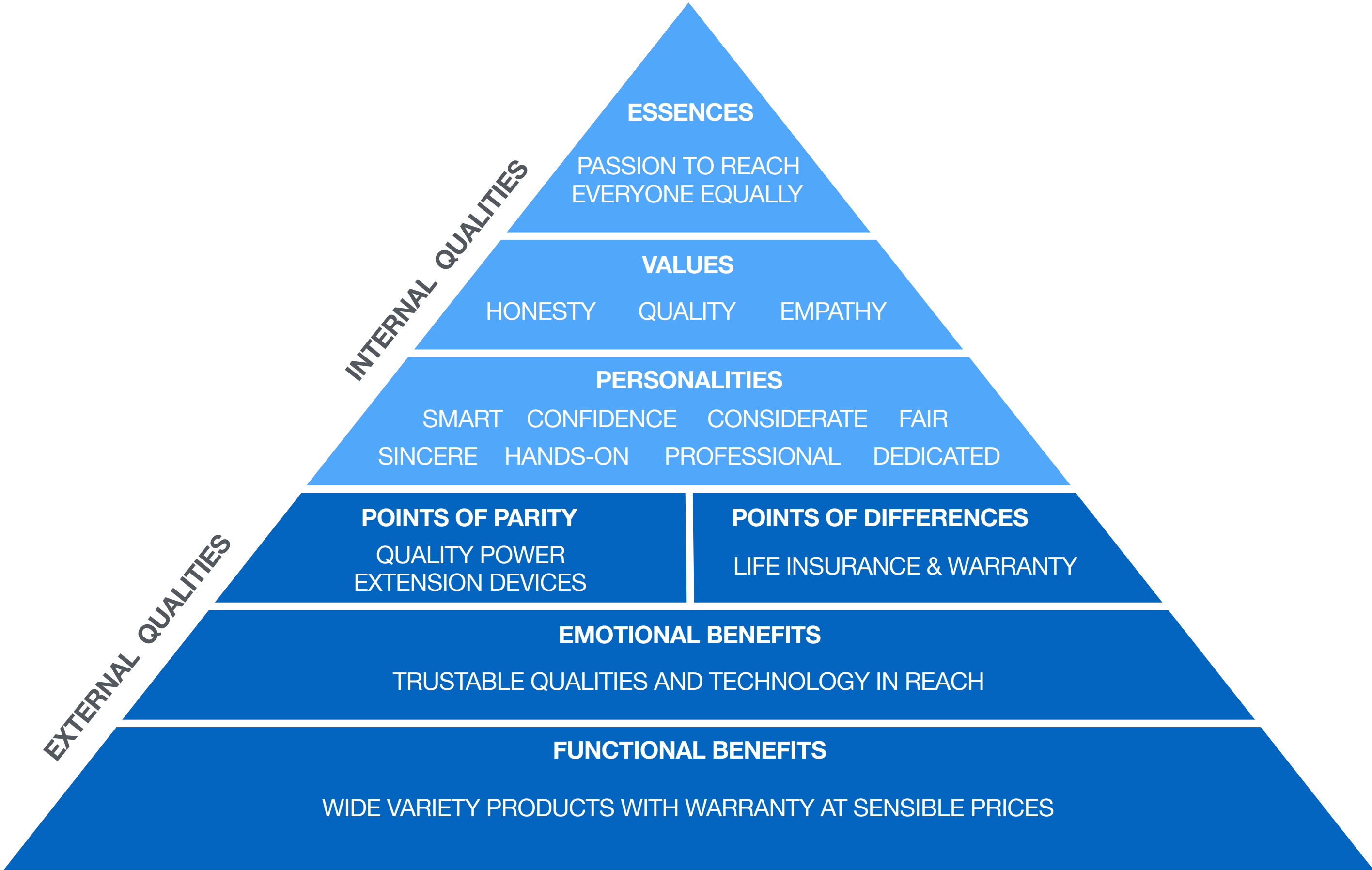

PERSONA MOOD BOARD

2024

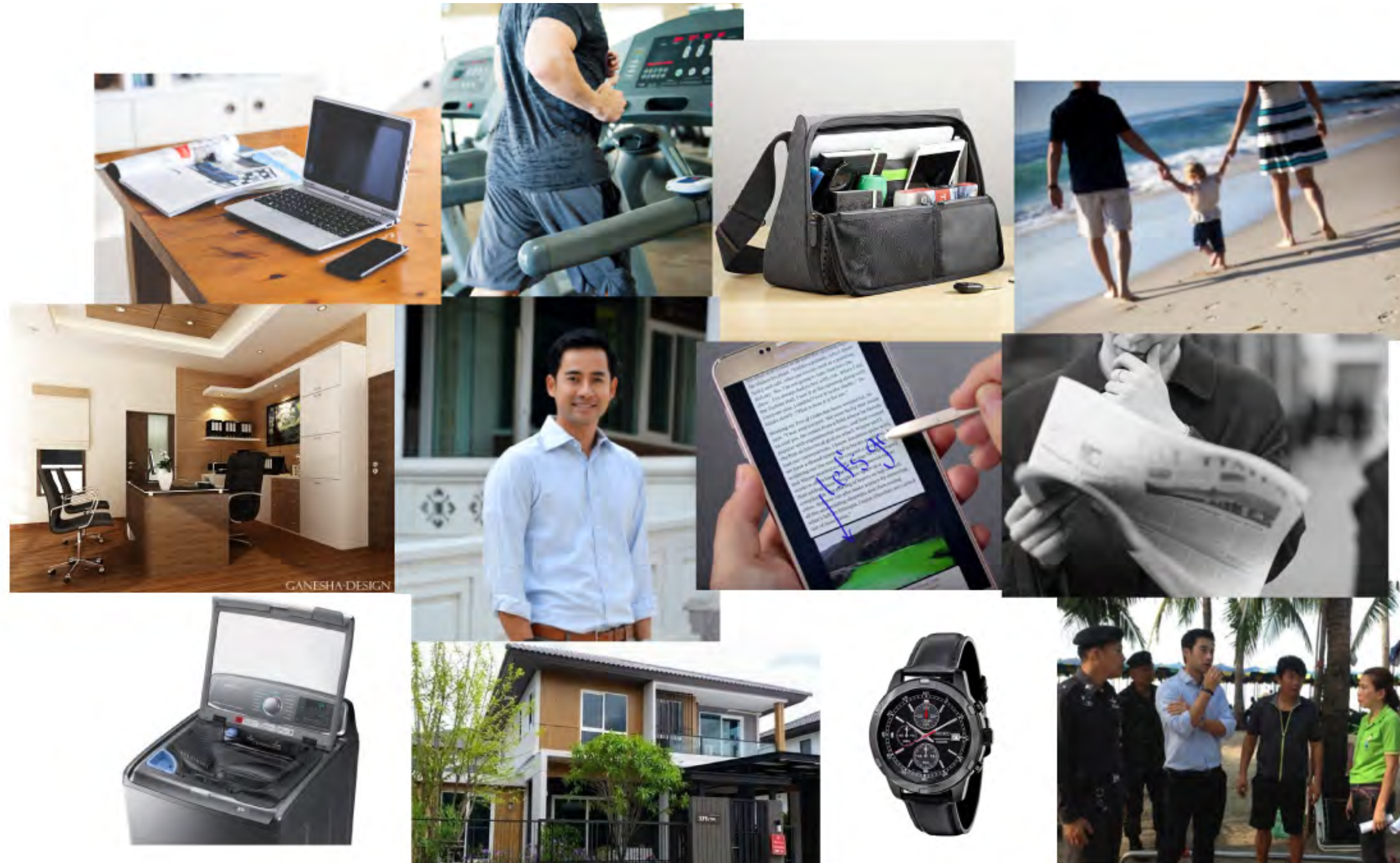

DATA
TRUSTED POWER



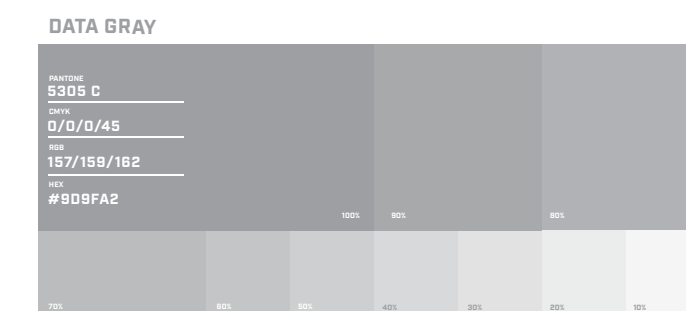
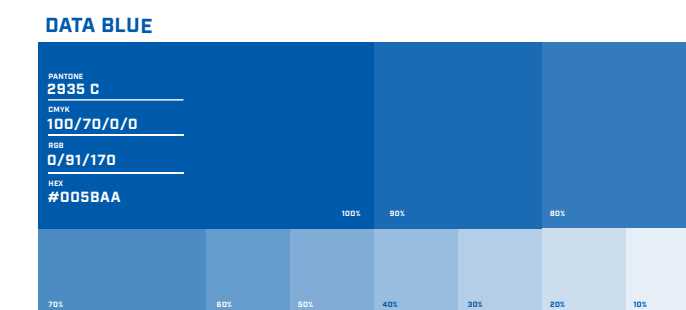

DATA

DATA POWER has been well known for their colorful power outlet models that were popular for the lifestyle buyers such as university students. For this product range, the new design uses plastic pouch instead of blister pack for a younger look and emphasizes on the concept of connectivity, as the power outlet is the hub that connects power to electrical devices. Therefore, using dynamic gradient color strips to represent the delivery of power and also connect the branded products together when placed on the shelf. Creating an impactful perspective at the point of purchase and offering new twist of creativity for the electrical power outlet product category.



 **MARINO DESIGN**



 **MARINO DESIGN**®



Spacing concerns

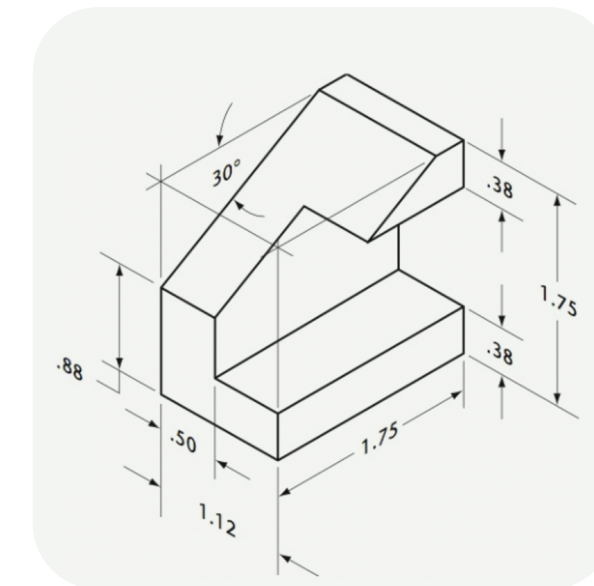

Idea of Products
and services

The logo consists of three vertical bars of varying heights, with the tallest bar on the left and the shortest on the right, creating a stylized 'M' shape.

MARINO DESIGN



 MARINO DESIGN®



SETHINI
INTERIOR DESIGNER

 MARINO DESIGN



STAFF PASS
ID | 12845688



MARINO DESIGN



20 IDEAS FOR KITCHEN

TRUST
STG
REA
KIC

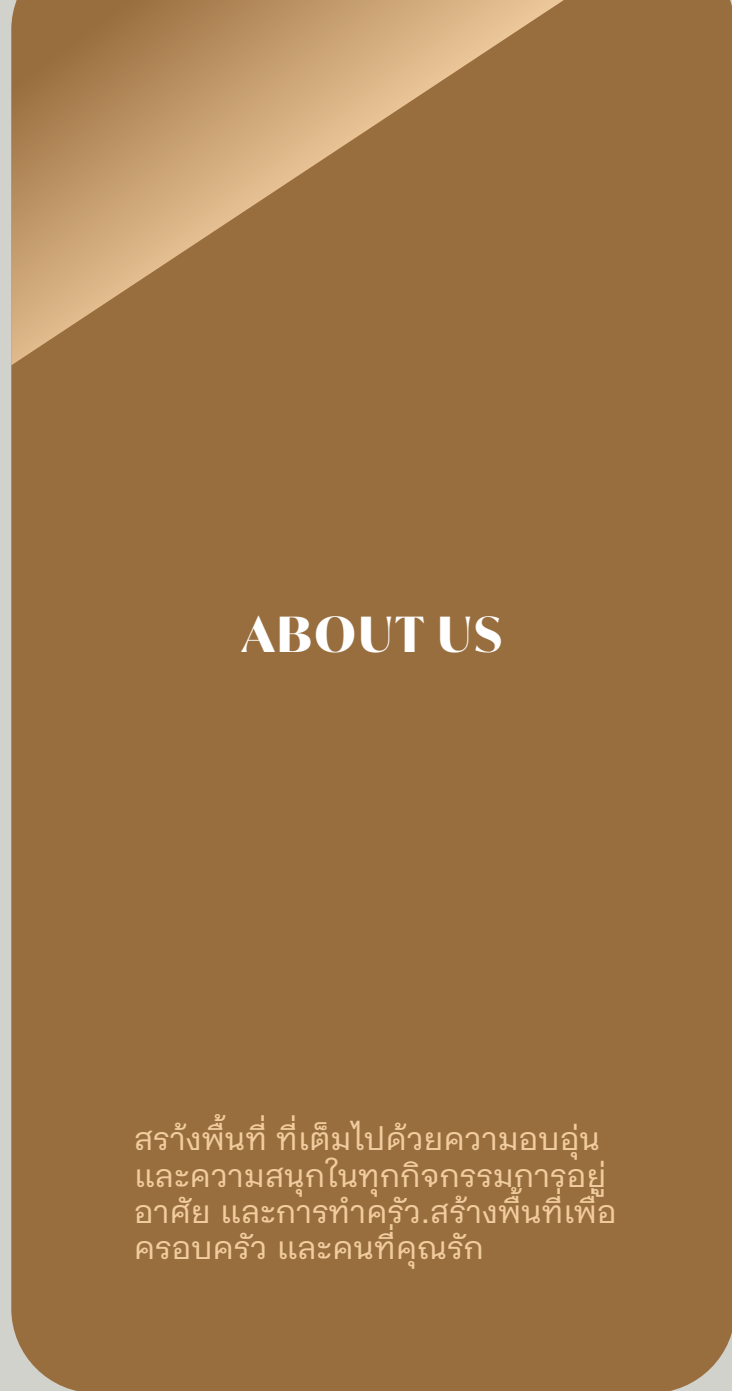

ABOUT US

สร้างพื้นที่ ที่เต็มไปด้วยความอบอุ่น และความสุขในทุกกิจกรรมการอยู่อาศัย และการทำครัว. สร้างพื้นที่เพื่อครอบครัว และคนที่คุณรัก



MARINO DESIGN



NATURAL MOODS



CONTACT US

If you have a question. Don't hesitate to talk with us. Send us a message



MARINO BATH

RECREATIONAL

สร้างพื้นที่ ที่เต็มไปด้วยความอบอุ่น และความสุขในทุกกิจกรรมการอยู่อาศัย และการทำครัว. สร้างพื้นที่เพื่อครอบครัว และคนที่คุณรัก

Creating spaces that bring warmth and joy into everyday cooking and living. Creating space for family and friends



MARINO DESIGN

TRUST
STG
REA
KIC



MARINO CABINET

TIMELESS AUTHENCITY

Creating spaces that bring warmth and joy into everyday cooking and living. Creating space for family and friends



"Producer of the year is awarded Kök. With a premium edge in the range as mass-produced kitchens Kök has opened up an interesting within design kitchens."

- RESIDENCE MAGAZINE



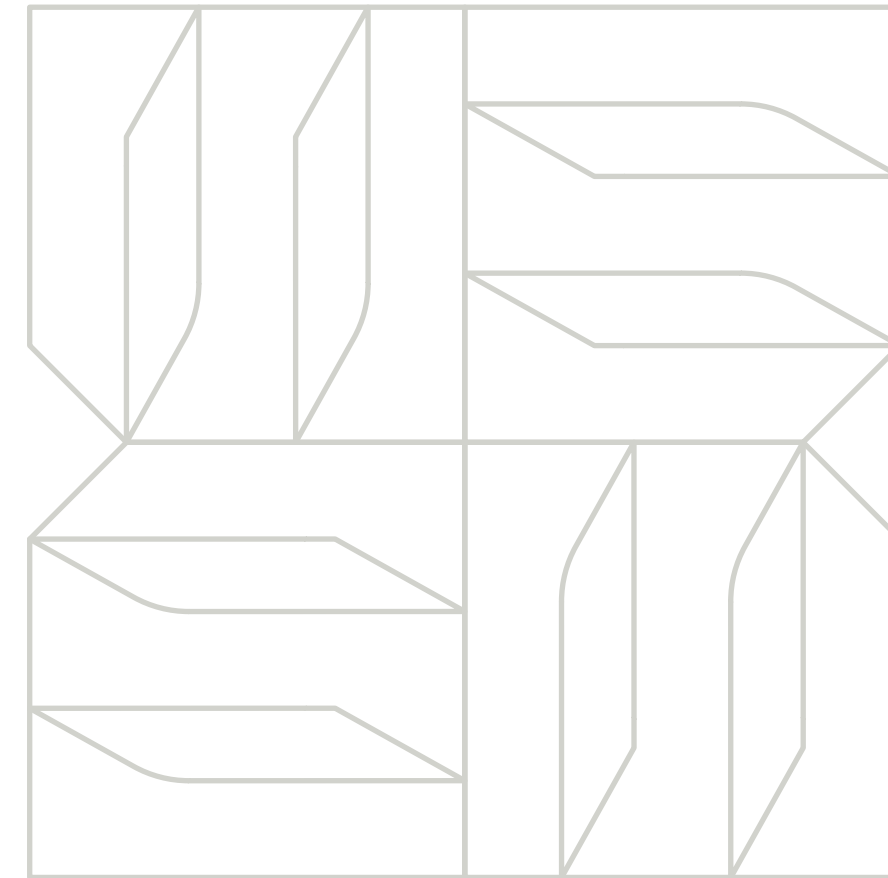

The image features a vibrant, multi-colored background with soft, wavy gradients of blue, teal, green, and orange. In the center, a solid black square contains the word "LAB" in a white, bold, sans-serif font. The letters are slightly stylized, with the 'A' having a unique shape. The overall aesthetic is modern and digital.

LAB



LAB

VOL. 01
LOVE OVER THE LONG LOVE
CREATORS: GOOD DAYS & ROUND STUDIO

VENUE
SUTTAJUMAS ROAD, PRATYAMANK
BKK, THAILAND

THE EYE CATCHER

DESIGNED BY
GOOD DAYS & ROUND STUDIO
PHOTOGRAPHY BY
MARTIN WILSON
ART DIRECTION BY
MARTIN WILSON
PUBLISHED BY
LAB

COLLECTOR'S EDITION
LIMITED TO 1000
X 2023



**THAILAND
CONTENT
LAB**

65 Soi Sureetorn, Ratcharaj Rd.,
Ladprao, BKK

+66.8922.0092

**PLOY
PARNTIP**

**SURIYA
SANGPITAKKUL**

**THAILAND
CONTENT
LAB**

65 Soi Sureetorn, Ratcharaj Rd.,
Ladprao, BKK

+66.8902.9833

**SURIYA
SANGPITAKKUL**

**THAILAND
CONTENT
LAB**

65 Soi Sureetorn, Ratcharaj Rd.,
Ladprao, BKK

+66.8902.9833

**SURIYA
SANGPITAKKUL**

**THAILAND
CONTENT
LAB**

65 Soi Sureetorn, Ratcharaj Rd.,
Ladprao, BKK

+66.8922.0092

**PLOY
PARNTIP**

65 Soi Sureetorn, Ratcharaj Rd.,
Ladprao, BKK

+66.8922.0092

**PLOY
PARNTIP**

eic

ENTERTAINMENT
INNOVATION
CENTER



45 / 45 / 45



255 / 255 / 255



250 / 50 / 0



250 / 145 / 0

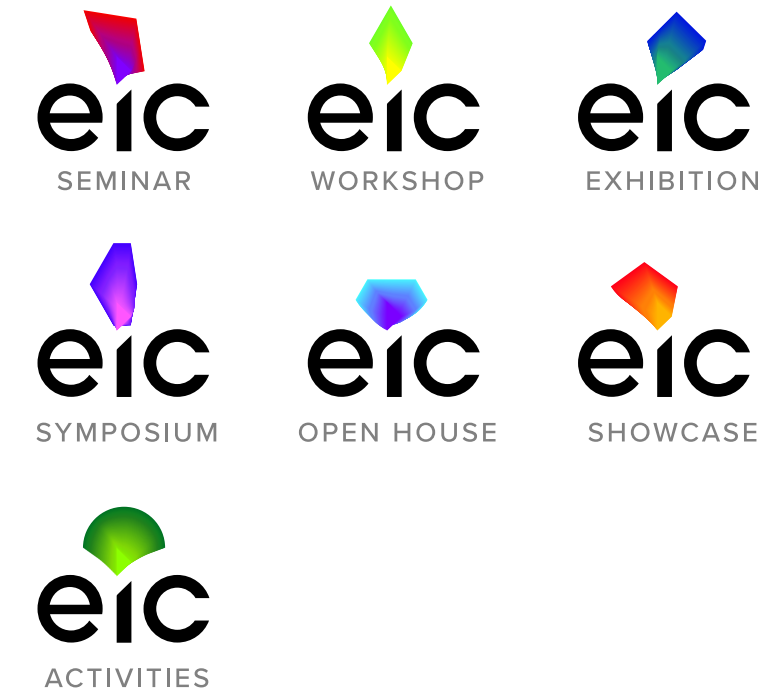
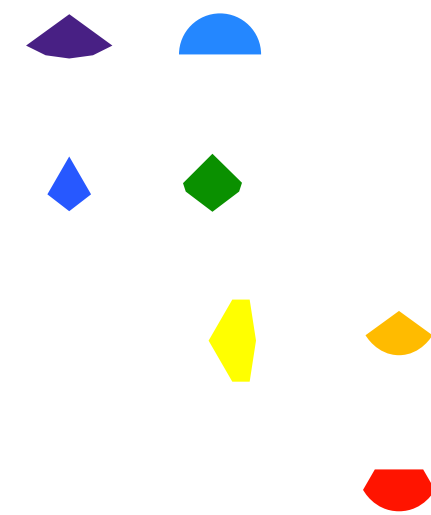
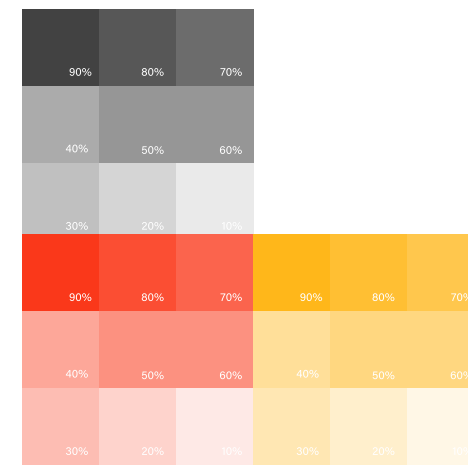
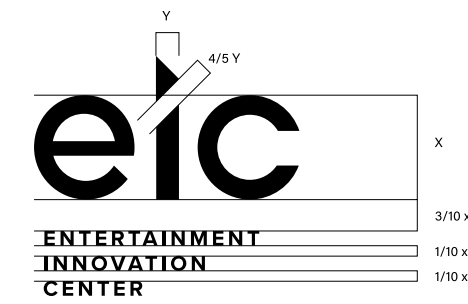

EIC

EIC offers a Master of Science (M.S.) Degree in Entertainment Innovation for specialization across all mediums in arts and technology. Using shapes of connection to create new form which represent creativities and innovation.

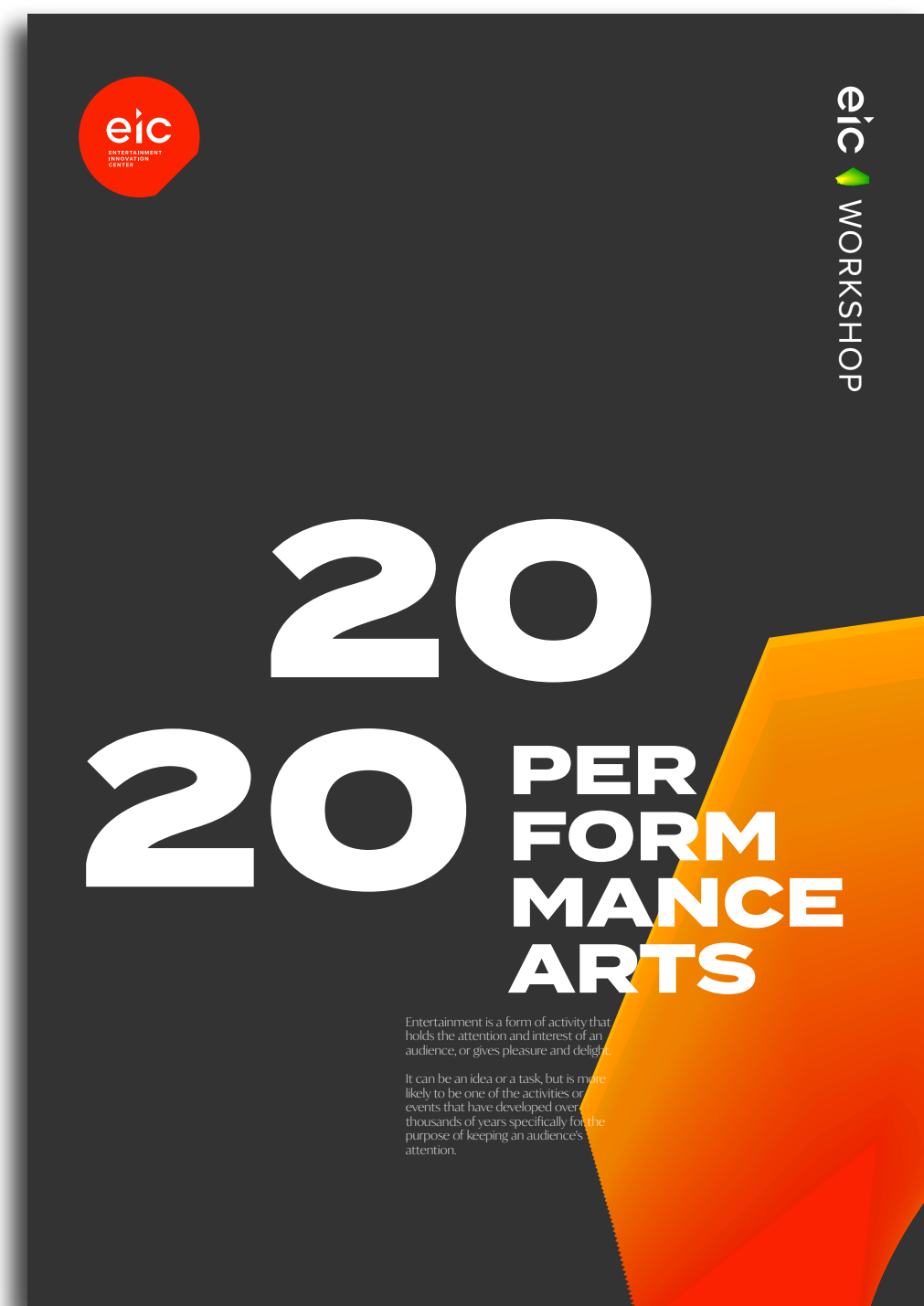
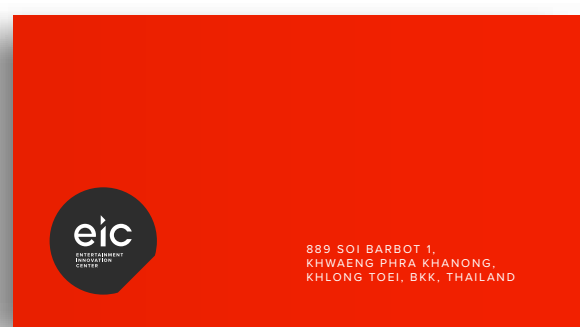
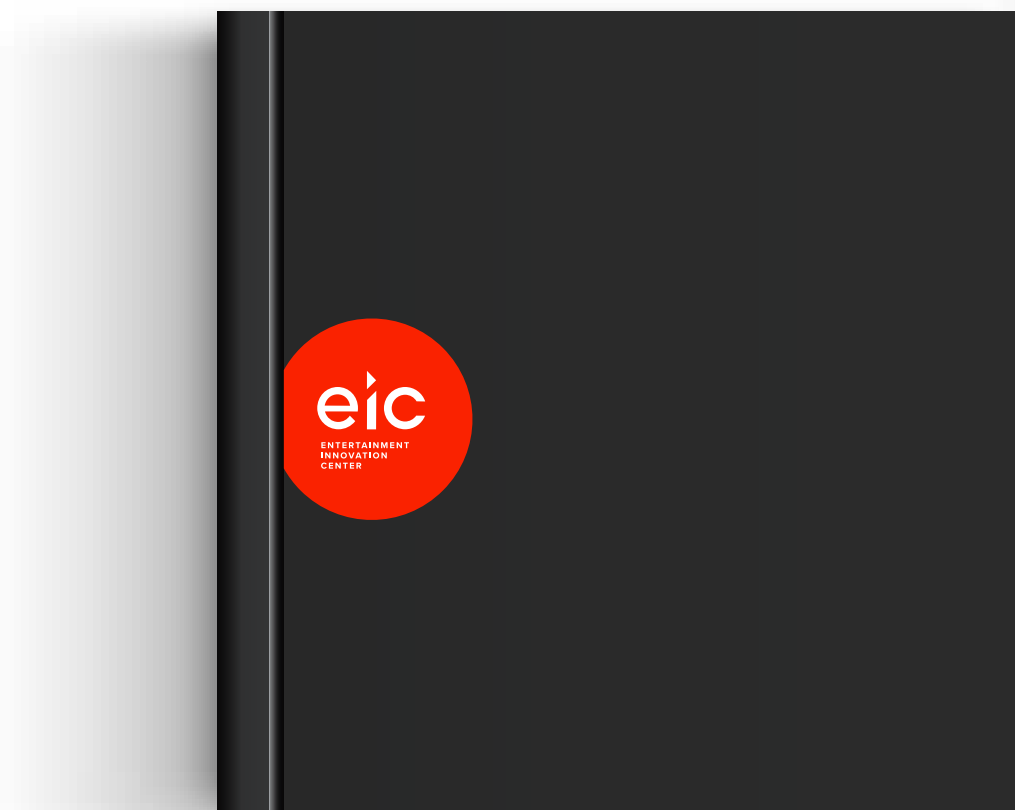

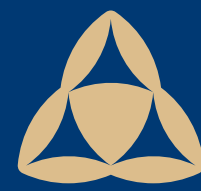

SOVA

HOTEL

VERTICAL LOGO



HORIZONTAL LOGO

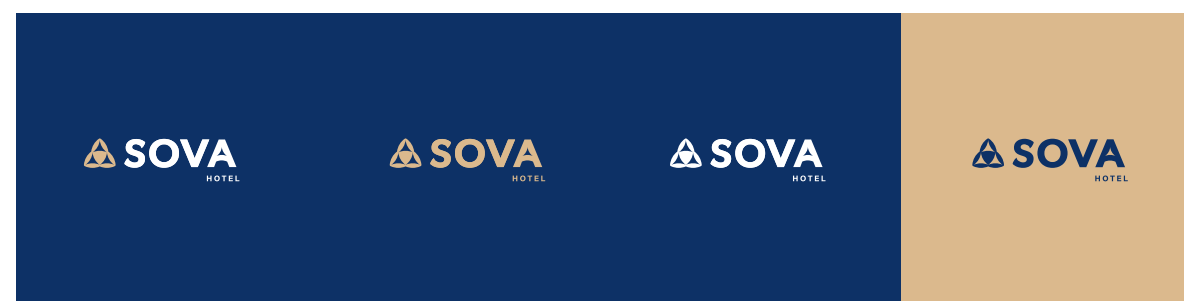

SOVA KRAM

PMS
PANTONE 541 C
CMYK
100 / 58 / 9 / 46

RGB
0 / 60 / 113
HTML
#003C7

TOA
7349 CITY NIGHT

SOVA NUAL

PMS
PANTONE 467 C
CMYK
6 / 15 / 41 / 10

RGB
211 / 188 / 141
HEX
#D3DC8D

TOA
8506 DUSTY TRAIL

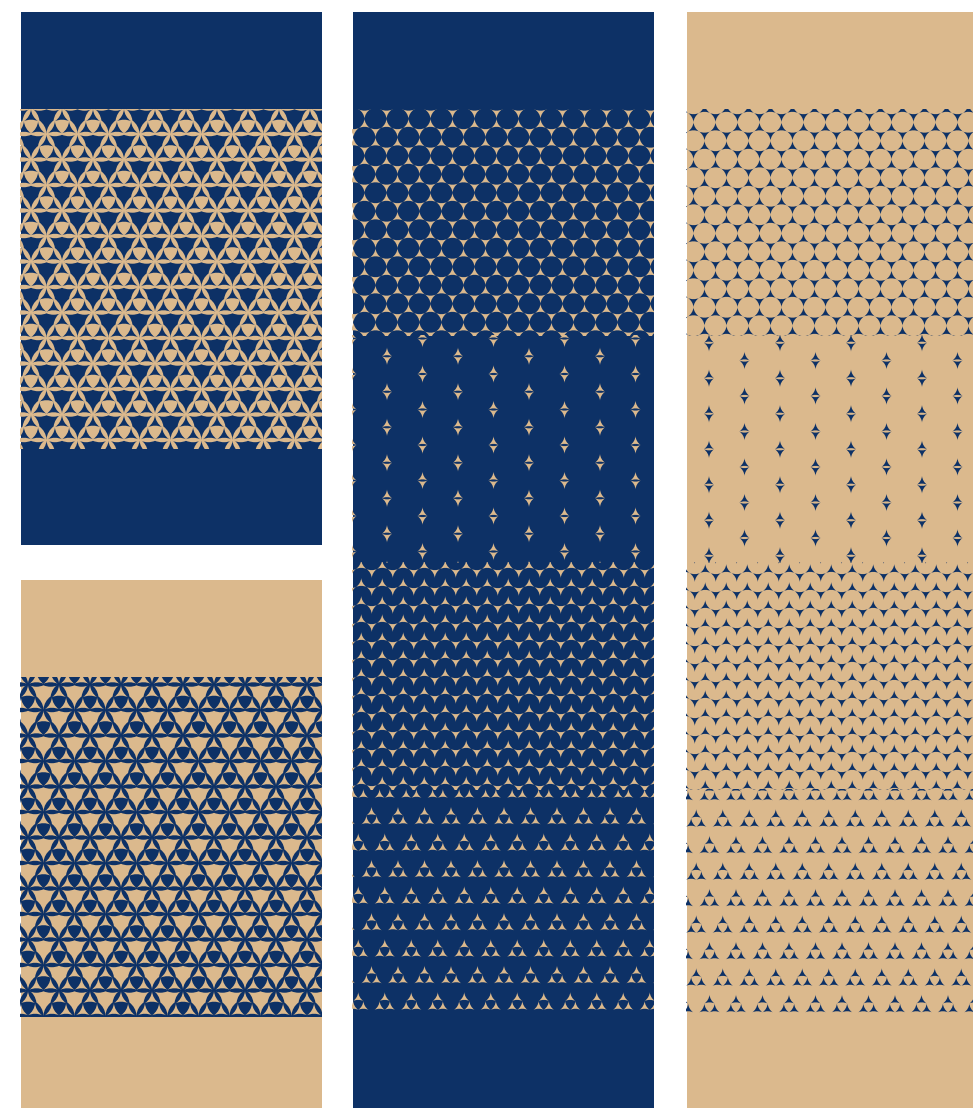

BRANDON GROTESQUE

SEVICES LOCAL FRIENDS

Lorem ipsum dolor sit amet, consectetur adipiscing elit, sed diam nonummy nibh euismod tincidunt ut

Lorem ipsum dolor sit amet, consectetur adipiscing elit, sed diam nonummy nibh euismod tincidunt ut laoreet dolore magna aliquam erat volutpat. Ut wisi enim ad minim veniam, quis nostrud exerci tation ullamcorper suscipit lobortis nisl ut aliquip ex ea commodo consequat. Duis autem vel eum iriure dolor in hendrerit in vulputate velit esse molestie consequat, vel illum dolore eu

veniam, quis nostrud exerci tation ullamcorper suscipit lobortis nisl ut aliquip ex ea commodo consequat. Duis autem vel eum iriure dolor in hendrerit in vulputate velit esse

We would like to just tell you a little bit about ourselves that we are a small family business

“Pull out Quote. Lorem ipsum dolor sit amet, consectetur adipiscing elit, sed diam nonummy”

Lorem ipsum dolor sit amet, consectetur adipiscing elit, sed diam nonummy nibh lobortis nisl ut aliquip ex ea commodo

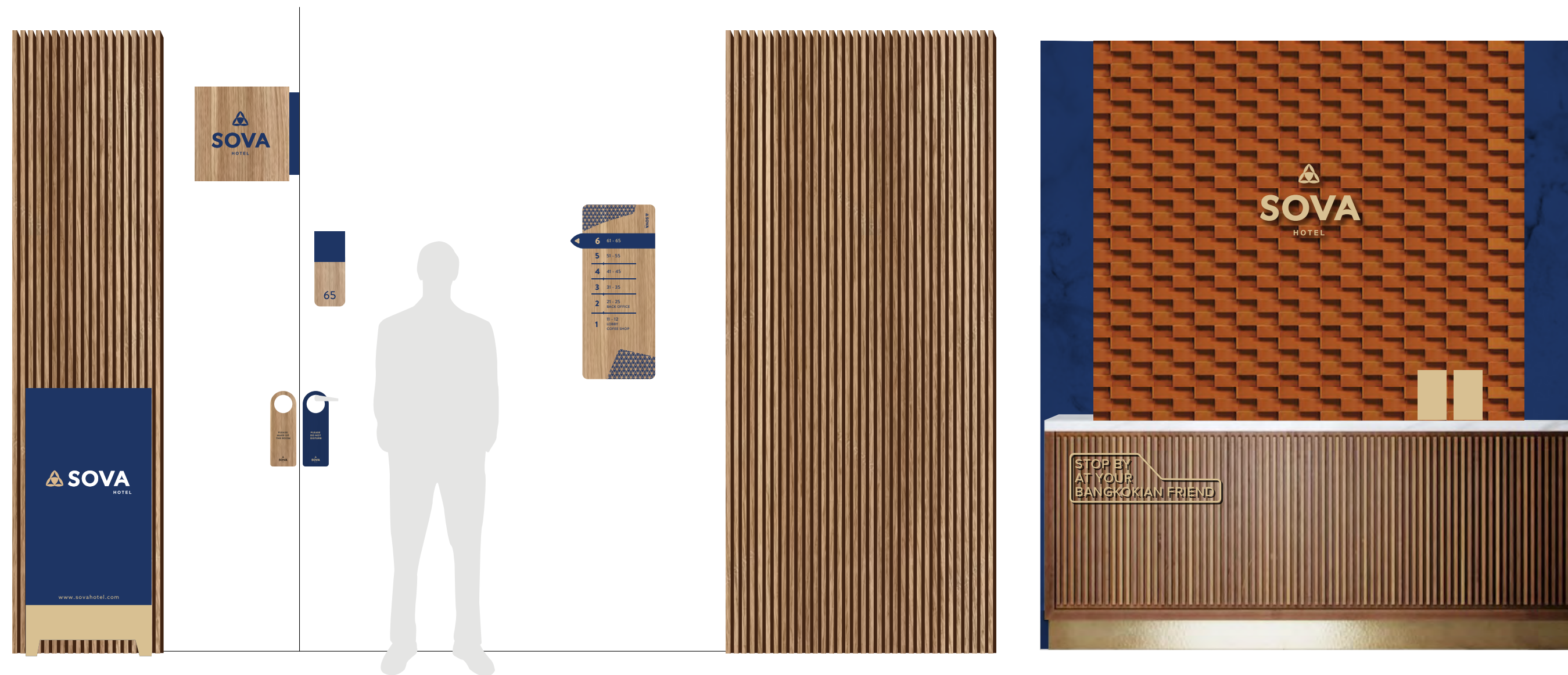

SOVA HOTEL

"The Rest stop at your local friend's" Sova Hotel is a small boutique accommodation located in the middle of Sukhumvit 24. Offering the quality hotel service with a touch of Thai contemporary style. Owned by a family business, they provide friendly service and eager to welcome their friends to stay comfortably and have an enjoyable time in Bangkok.



PHAT CAT
RECORDS



DB Helvethaica X 75 Bold / DB Helvethaica X 55 Regular

แจ๊สเสียงจิ้งหะ ดนตรีสู่พลังแห่งความรัก

อันเป็นเอกลักษณ์ของการร้องและ
ท่วงทำนองที่เกิดจากเครื่องดนตรี
ที่มีคุณภาพมีรูปแบบที่สามารถ
พัฒนาไปสู่เสียงแบบต่างๆ อย่าง
เป็นอิสระ ไม่มีรูปแบบตายตัว

DIN Condensed Bold / Proxima Nova Regular and Semibold

JAZZ MUSIC ENHANCEMENT

Melody
Rhythm
Movement
Sound

Although jazz is considered
difficult to define, in part because
it contains many subgenres,
improvisation is
one of its key elements.
The centrality of improvisation is
attributed to the influence
of earlier forms of music

PHAT CAT RECORDS

Phat Cat Records, the new and refreshing jazz label with their own unique sound. With its brand name and characteristics, the cat symbol perfectly represents the jazz musicality. Using the feline silhouette along with the trumpet shape as the formal identity while the cat face can be applied playfully.



CONCEPT & PATTERN DESIGN

AIS

AIS would like to send Happy New Year gifts to their business partners and suppliers while also promoting their CSR Sustainability campaign. We created the creative concept, NETWORK OF GREEN, which illustrate the connection and good relationship of AIS with their partners that achieve the success in expanding their network and services. The origami bird symbolize the messenger of good will which spread out both prosperity and connectivity for both partners and clients.



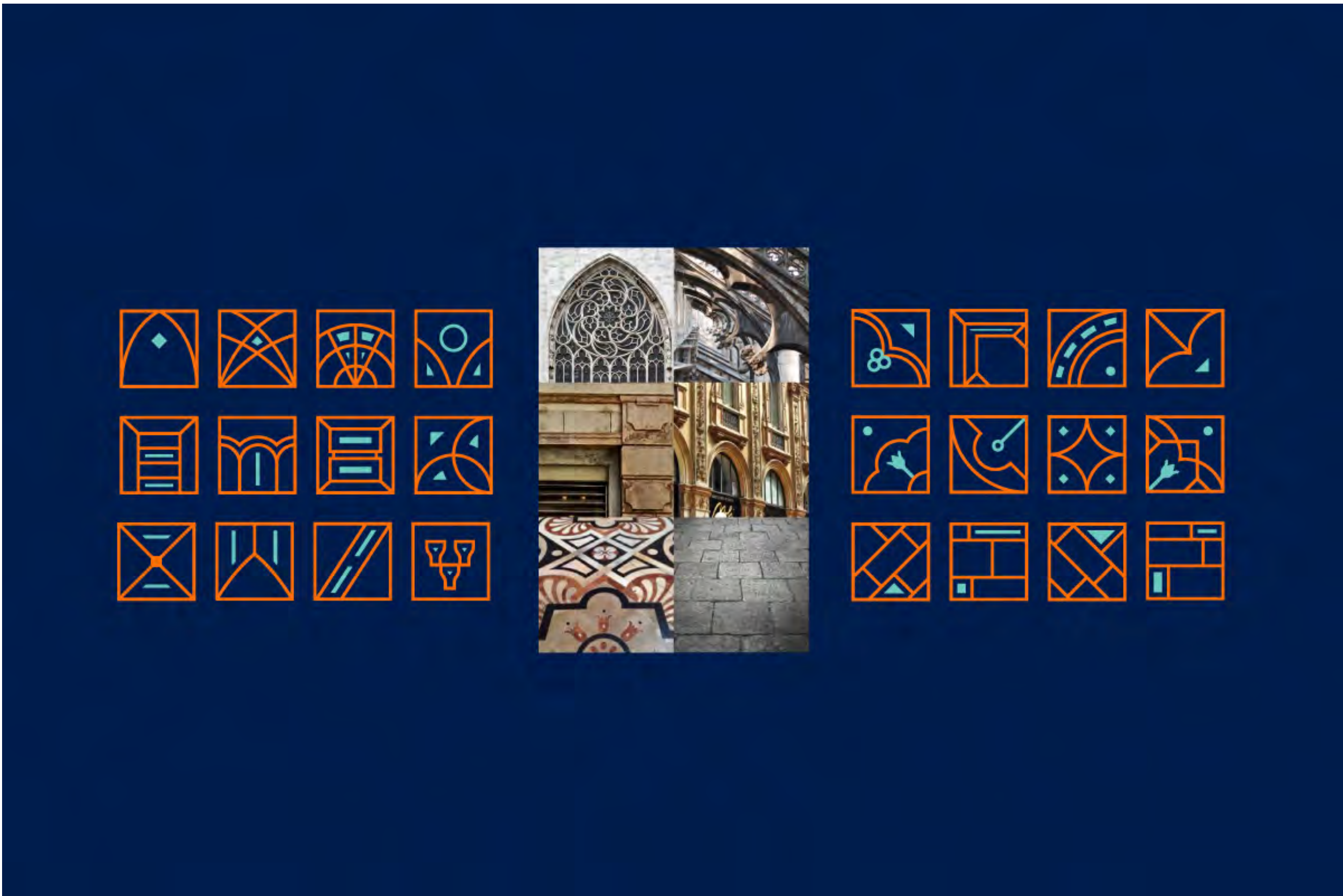

IDENTITY DESIGN

NUVOLA

Contemporary style integrated with traditional Italian culture. Serious and Sophisticated about our cuisine yet smartly playful about the atmosphere and service. Warm-heartedly welcomes anyone, anytime to any section of the place as everywhere is part of the home.

BINE

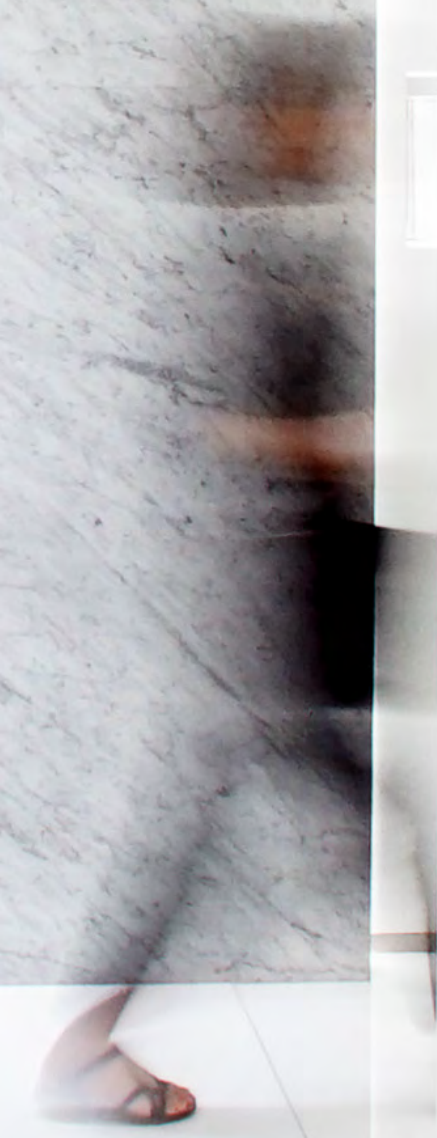

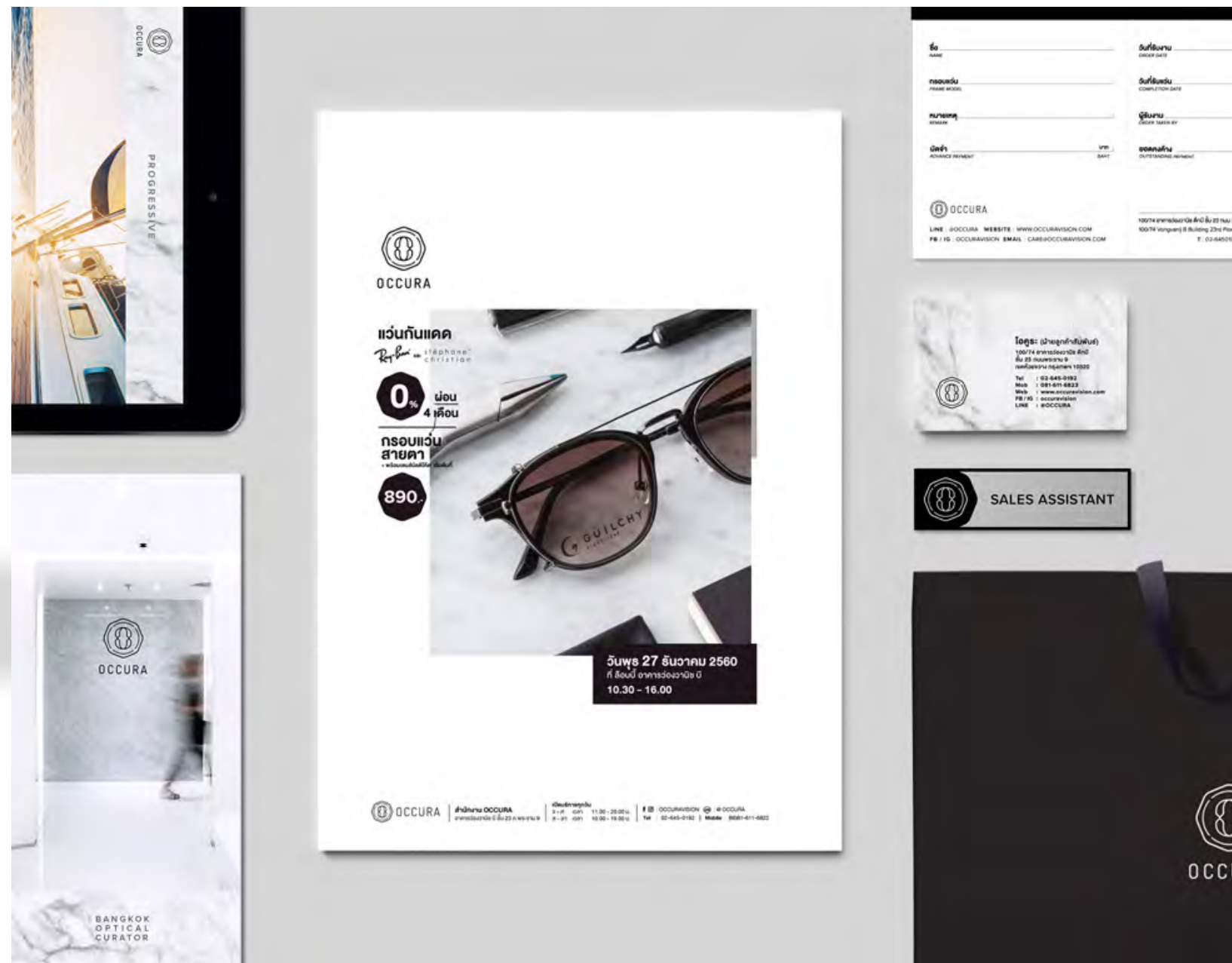
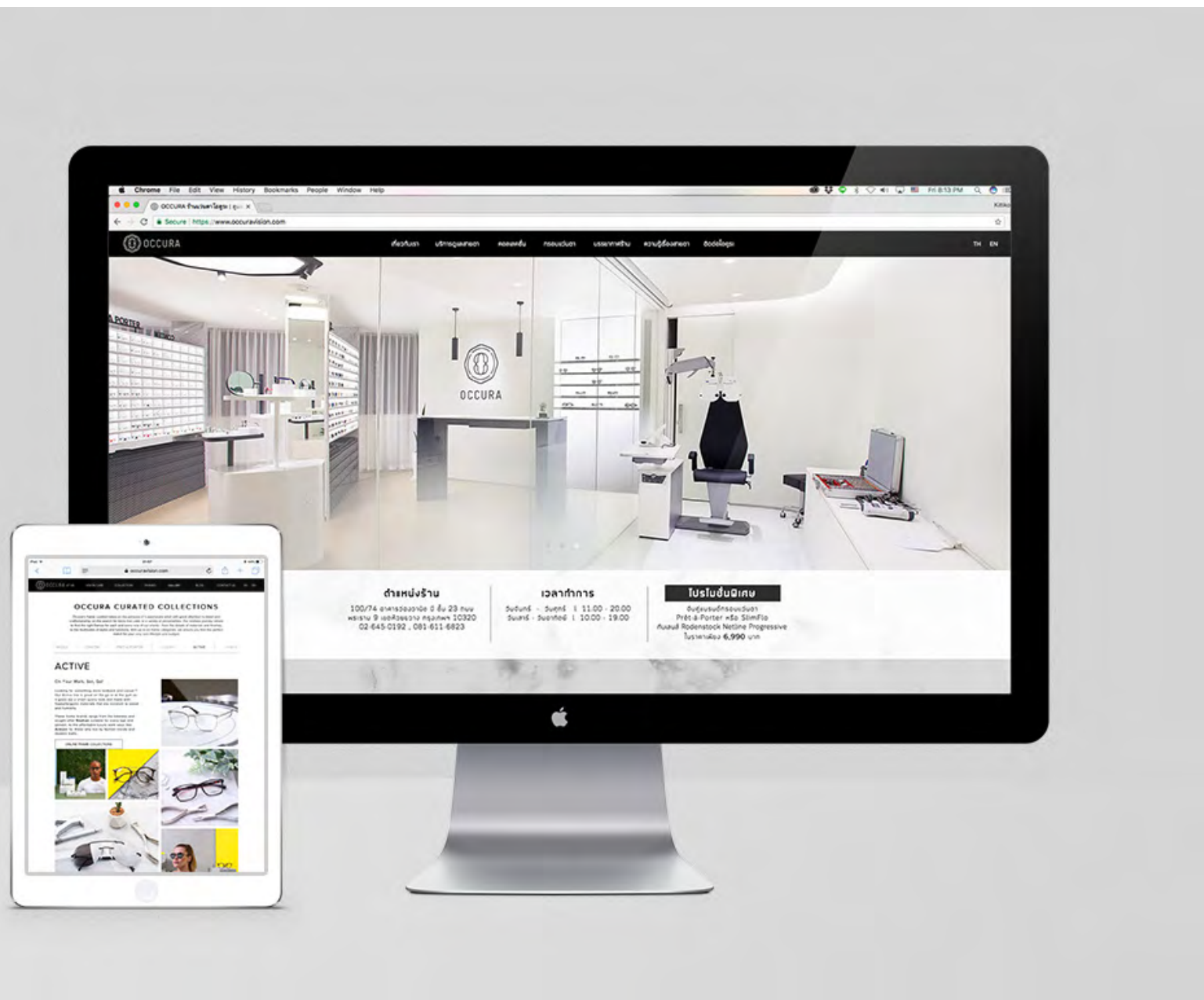

OCCURA

OCCURA's name came from the combination of "Oculli" and "Cura" which mean "curing of the eye". The core passion of OCCURA is to ease the customers' eyesight condition by recommending the optimal eyewear solution for each individual customer according to their unique lifestyle.

The identity is inspired by vesica piscis, the eye shape and the letter "O" as OCCURA requires both art and science to prescribe the aesthetically enhancing frames and correct optometric solution.



EMPEROR



EMPEROR GREEN	EMPEROR BEIGE	EMPEROR DARK GREY	EMPEROR LIGHT GREY
PANTONE 3435 C	PANTONE 468 C	PANTONE COOL GREY 10 C	PANTONE COOL GREY 4 C
CMYK 100 40 100 70	CMYK 0 10 40 10	CMYK 0 0 0 85	CMYK 0 0 0 35
RGB 0 46 0	RGB 235 216 155	RGB 64 64 64	RGB 166 166 166
HEX #002E00	HEX #EBD89B	HEX #404040	HEX #A6A6A6



EMPEROR

The Emperor House, the creator of elegant homes with specialty in classical styles. Offering the best value by their team of expertise, creating more than just a house but a phenomenon for their clients and their families.



ARIA
BY LAYANA
DEVELOPMENT

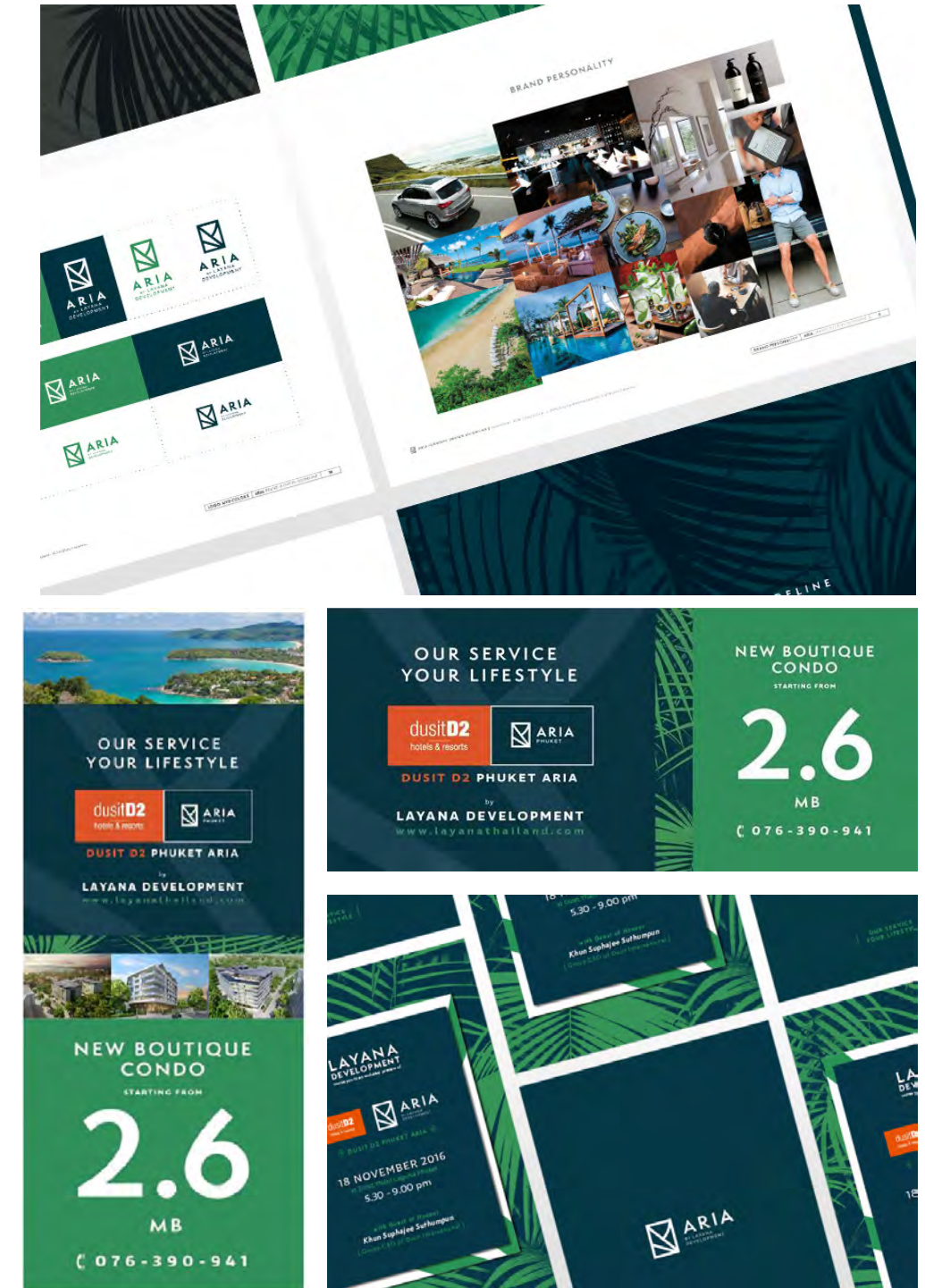
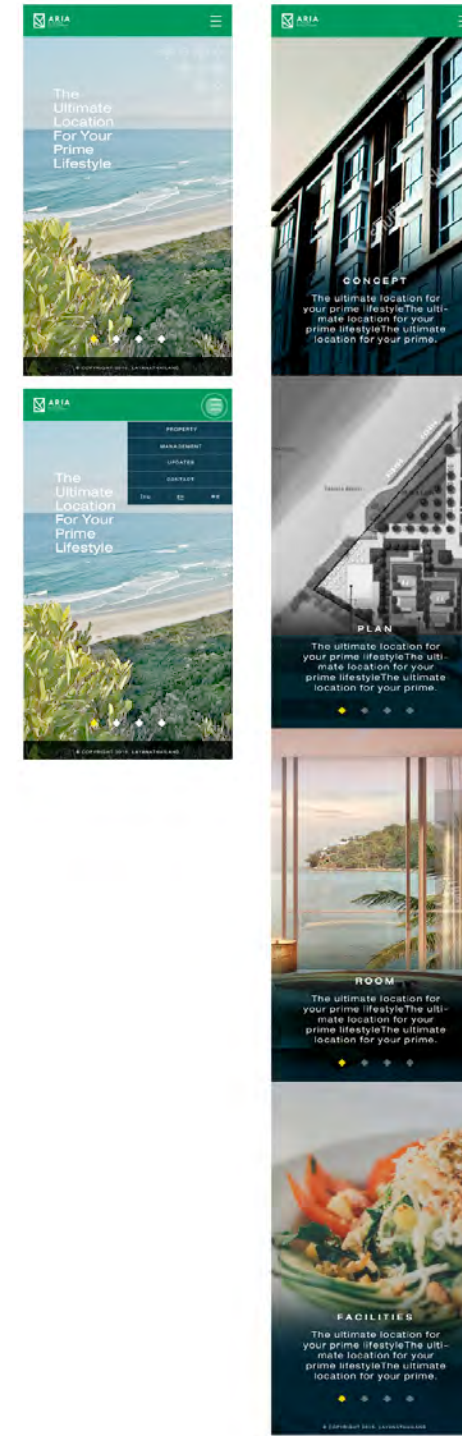

ARIA by Layana

The serviced condo/hotel in the prime location of Phuket, Thailand where modern lifestyle meets with the serene scape of Surin and Bangtao beaches. Representing the modern architectural structure that captures the natural aspects inside. It can be perceived both ways as a window frame that looks out to opportunity and prosperity of sunshine or a vertical architecture that captures a leaf inside.



67°

67°

x

1/2x

Smiles
&
JAZZ & BISTRO





SMILES

Founded by a jazz artist and her devotion to music, she wants to create a place that represents her passion and vision. This is the jazz club that welcomes musicians and audiences to share the music experiences together in the contemporary settings of Bangkok.

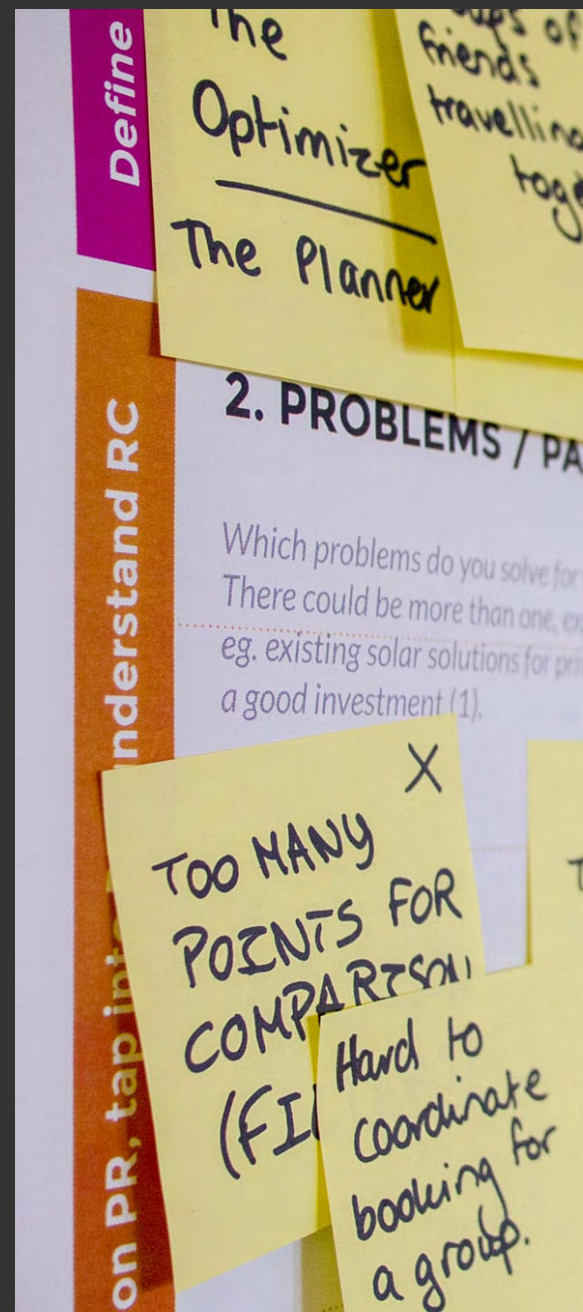

BRANDING



IDENTITY DESIGN



ENVIRONMENTAL DESIGN



PACKAGING DESIGN

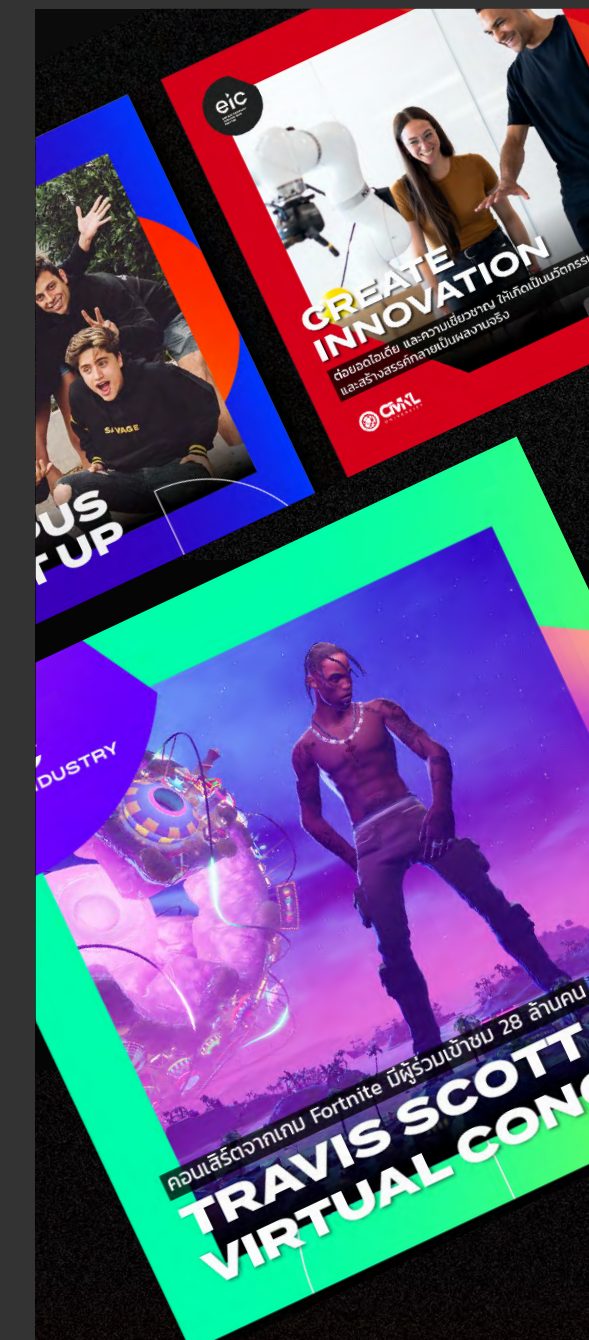

SOCIAL MEDIA MARCOM

